

Installation Manual

P-300

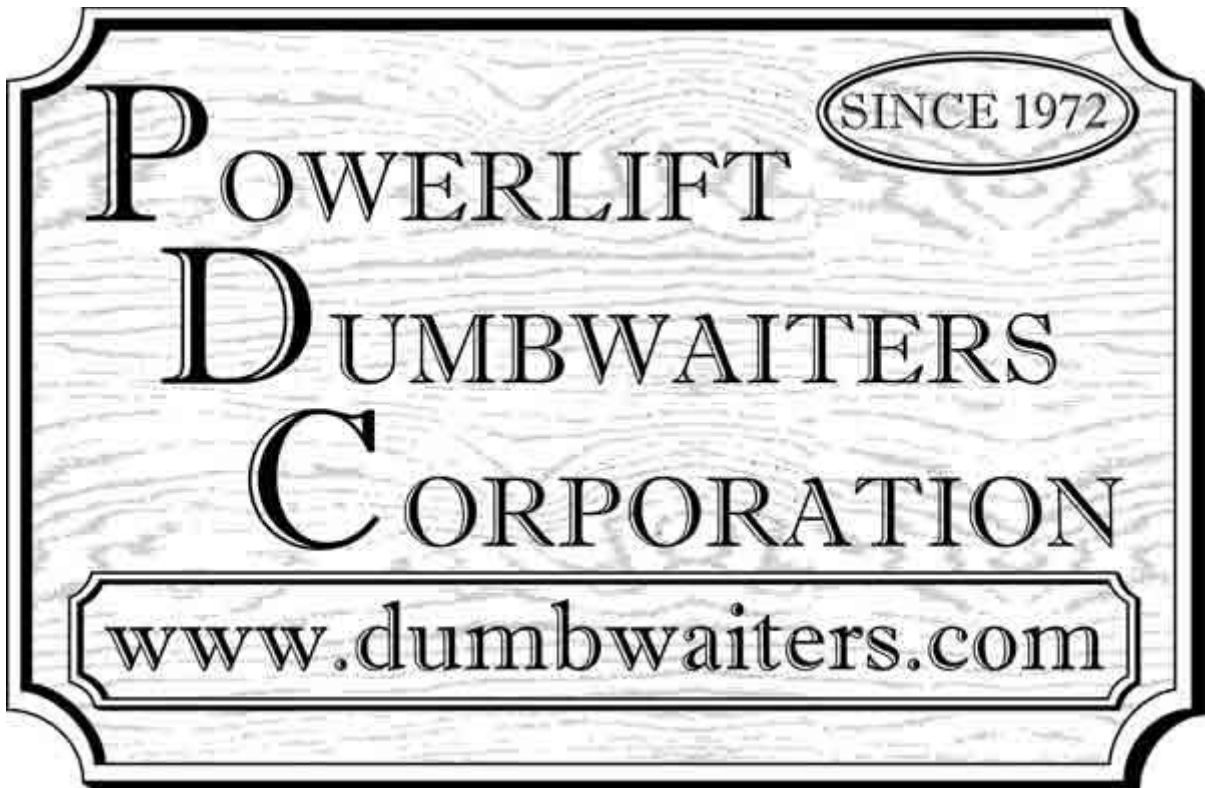

2444 Georgia Slide Road, Georgetown, CA 95634
800-409-5438 • 530-333-1953
Fax: 530-333-1055





Congratulations and thank you for purchasing a Powerlift Dumbwaiter! We are a family owned company, in business for over 40 years, with a commitment to excellence and our customers. Should you have questions or concerns, please do not hesitate to contact us on our toll-free number. We offer free technical support through all phases of your dumbwaiter installation and our staff will be happy to help you.

This installation manual includes information for installing most configurations of the **P-300** and therefore not all information included will apply to your installation. If you are uncertain which configuration you are installing or have any questions, please call us.

Serial # _____

Table of Contents

Important Information _____	5
Dumbwaiter Packaging Contents _____	6
Recommended Wall Backing _____	7
Part 1a Motor Installation _____	8
Part 1b Connecting Wires to T-bar in Controller _____	9
Part 2a Track & Rail Installation (motor on the bottom) _____	10
Part 2b Track & Rail Installation (motor on the top) _____	11
Part 3a Gearbox Breather Installation (motor on the bottom) _____	12
Part 3b 3 Phase Motor Rotation (motor on the bottom) _____	13
Part 3c Chain Installation (motor on the bottom) _____	14
Part 3d Gearbox Breather Installation (motor on the top) _____	15
Part 3e 3 Phase Motor Rotation (motor on the top) _____	16
Part 3f Chain Installation (motor on the top) _____	17
Part 4 Wiring Track & Rail Assembly _____	18
Part 5 Rough Framing & Call/Send Wiring Rough in _____	19
Part 6a Finish Wiring (call/send push buttons & options) _____	20
Part 6b Finish Wiring (door interlock installation) _____	21
Part 6c Finish Wiring (door interlocks & safety switch) _____	22
Part 7 Installing Dumbwaiter Car _____	23
Troubleshooting _____	24
Wiring Diagram (2-stop single phase machines) _____	25
Wiring Diagram (2-stop three phase machines) _____	26
Wiring Diagram (Dynamic Brake / Single Phase) _____	27
Wiring Diagram (Dynamic Brake / Three Phase) _____	28
Wiring Diagram (3-stop single phase machines) _____	29
Wiring Diagram (3-stop three phase machines) _____	30
Wiring Diagram (4-stop single phase machines) _____	31
Wiring Diagram (4-stop three phase machines) _____	32

Important Information You Should Know

Please Read

1. Anyone planning to use this dumbwaiter should read the Owner's Manual prior to operating. If you do not have an Owner's Manual, please visit our website to download a copy or call us to have one sent to you.
2. **DO NOT allow children to use the dumbwaiter without adult supervision!**
3. **NEVER OPERATE DUMBWAITER if door interlocks or motor access safety switch are not working properly.** Every dumbwaiter includes door interlocks and a motor access safety switch, which prevent the dumbwaiter from operating if any door is not properly closed. The motor access safety switch will also stop the dumbwaiter if the motor access panel/door is opened while the dumbwaiter is in operation. If your door interlocks or motor access safety switch are not working properly, immediately turn off power to the dumbwaiter and call Powerlift Dumbwaiters, Inc. to request replacement door interlocks or safety switches. Ensure that the door interlocks or safety switch are replaced by a qualified technician.
4. **NEVER USE THE DUMBWAITER if it is not operating properly.** Call your service technician, installation contractor, or Powerlift Dumbwaiters, Inc.
5. **NEVER USE THE DUMBWAITER when smoke and/or fire is present.**
6. **DO NOT REMOVE, BYPASS, OR ALTER any switches, controls, and/or restraining devices.** These are mandated by national and local codes and safety regulations. Any tampering will void your warranty and could result in serious injury and/or death.
7. **NEVER EXTEND YOUR HANDS, ARMS, LEGS, FEET, HEAD, OR BODY INTO OPEN HOISTWAY!** Doing so could cause serious injury and/or death! Never extend foreign objects of any kind into open hoistway. Doing so can cause damage to your dumbwaiter and/or serious injury to you!
8. **NO RIDING IN DUMBWAITER CAR!** Your dumbwaiter car is not intended to transport people and/or animals. Doing so could cause serious injury and/or death!
9. **NEVER OVERLOAD YOUR DUMBWAITER CAR!** Your dumbwaiter is rated for a certain capacity. Please see data plate in car.
10. Your dumbwaiter is not designed for continuous operation. Too many "starts" and "stops" could overheat the motor and trip the breaker.
11. The single phase motor is designed to operate properly on a dedicated 230 volt circuit with a 20 amp breaker using 12 Ga wire for distances up to 50 feet and 10 Ga wire for distances up to 100 feet. The 208/230 volt 3 phase motor is designed to operate properly on a dedicated 10 amp breaker using 12 Ga wire for distances up to 150 feet. The 460 volt 3 phase motor is designed to operate properly on a dedicated 6 amp breaker using 12 Ga wire for distances up to 150 feet. In general distances in excess of 50 feet or too many appliances operating from the same power source reduces the available amperage and may cause the lift to malfunction unless a larger gauge wire is used. If your dumbwaiter does not seem to be operating at its optimum, stop using it until it can be inspected by a qualified technician.
12. To prevent unauthorized use, a keyed on/off switch can be obtained from Powerlift Dumbwaiters, Inc.
13. Observe, read, and obey the warning labels, tags, and symbols, as they are provided by the manufacturer for your safety and protection.
14. **DO NOT ATTEMPT TO REPAIR the dumbwaiter yourself.** Immediately stop use, shut off or disconnect power supply and call Powerlift Dumbwaiters, Inc. to determine whether you need to contact your service technician or installation contractor.
15. **Check your local fire code.** Swing Hoistway doors may be required to be fire rated and have self closing hinges.

Before You Begin Installation

Proper installation is the responsibility of the installer. A qualified technician should install this dumbwaiter. Make sure you have everything necessary for correct installation. It is the installer's responsibility to ensure the installation complies with the local codes and safety regulations.

Wall construction should be a minimum of 2" x 4" wood studs. Please see the recommended wall backing, on **Page 7**, for our recommended wall framing.

Check the dumbwaiter for damage. Remove all packaging materials and verify that everything is included using the following checklist.

I. In Motor Box:

- Motor
- RDI Door Interlocks – (1 interlock per opening)
- Parts Box

II. In Parts Box

- Installation Manual
- Owner's Manual
- Parts Bags

III. In Parts Bags

- Frame Clips – (1 frame clip per track section)
- 2" Coarse Screws for Frame Clips – (1 screw per frame clip)
- Stacking Pins – (2 stacking pins per track section, less top section)
- 3" Lag Screws – (quantity varies)
- ¼" x 2¼" Bolts & Flange Nuts – (quantity varies)
- Faceplate w/Push Buttons & 2 Faceplate Screws – (1 per opening)
- Wire Nuts – (quantity varies)
- Door Safety Switch & 2 Screws – (1 for motor access panel)
- Two (2) ¼"-20 x 1¾" Bolts & Washers for Mounting Car

Recommended Wall Backing

Vertical Backing for 16" wide Rails

Locate and mark centerline on the mounting wall. Measure and mark 6½" on both sides of centerline. These two marks, 13" apart, represent the centerline of your vertical backing. Install 2x6's centered on each mark with the 6" side facing into the shaft and running vertically up the entire shaft.

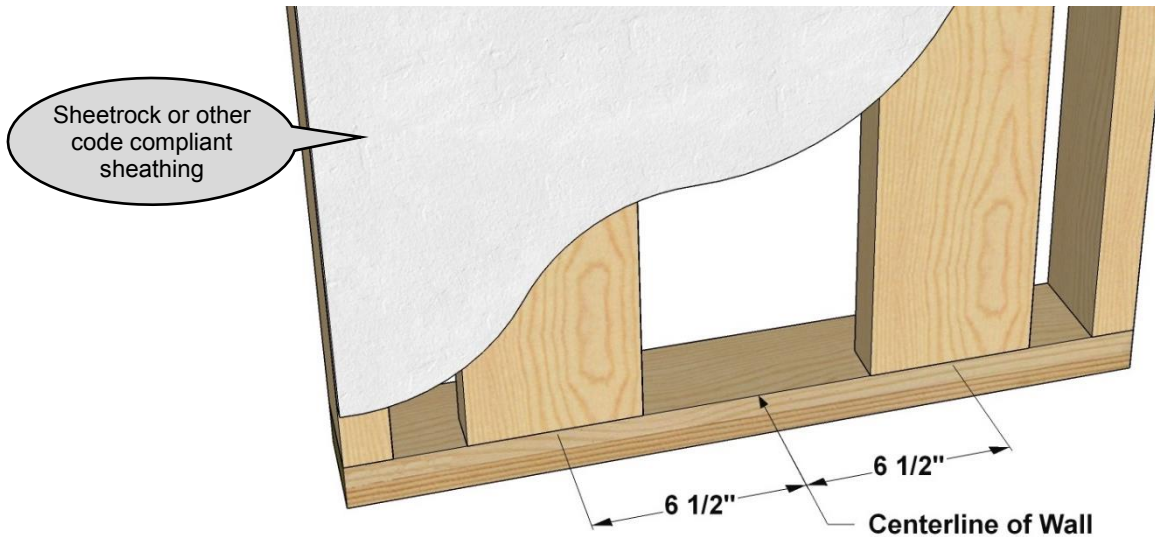

Vertical Backing for 20" wide Rails

Locate and mark centerline on the mounting wall. Measure and mark 8½" on both sides of centerline. These two marks, 17" apart, represent the centerline of your vertical backing. Install 2x6's centered on each mark with the 6" side facing into the shaft and running vertically up the entire shaft.

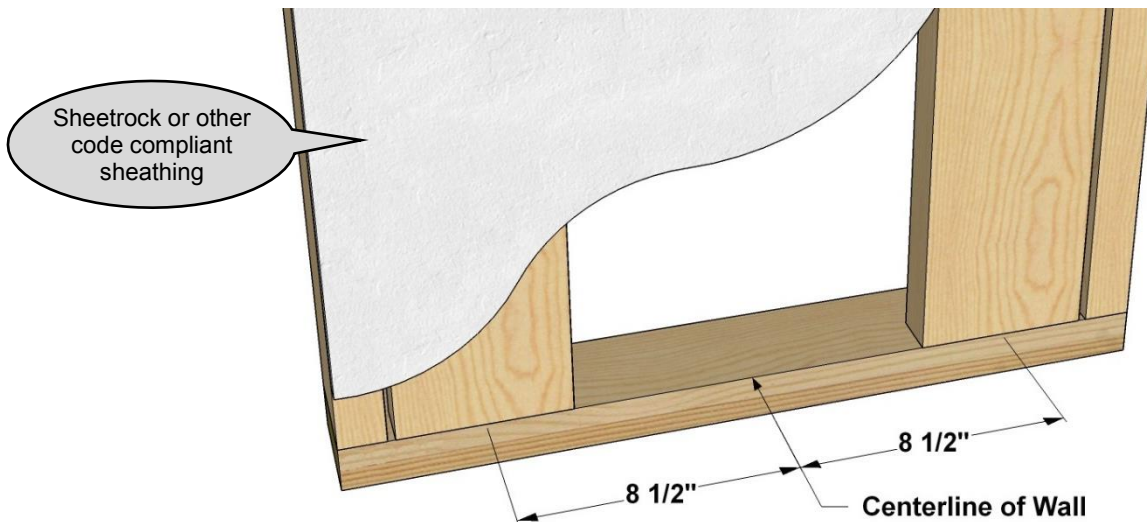

PART 1a

Motor Installation

- 1** Place motor section of track horizontally on a flat surface.
- 2** Remove motor from box and place it on track & rail section from Step 1. (see Figure 1)
- 3** Use four (4) washers, and nyloc nuts to securely fasten motor to track & rail section. (see Figure 1)
- 4** Use factory installed wires from junction box, on the rail next to the motor, to wire in the motor controller. (see Figure 1)

Note: Use the wiring diagram, on Page 9, to properly connect the wires to the T-bar.

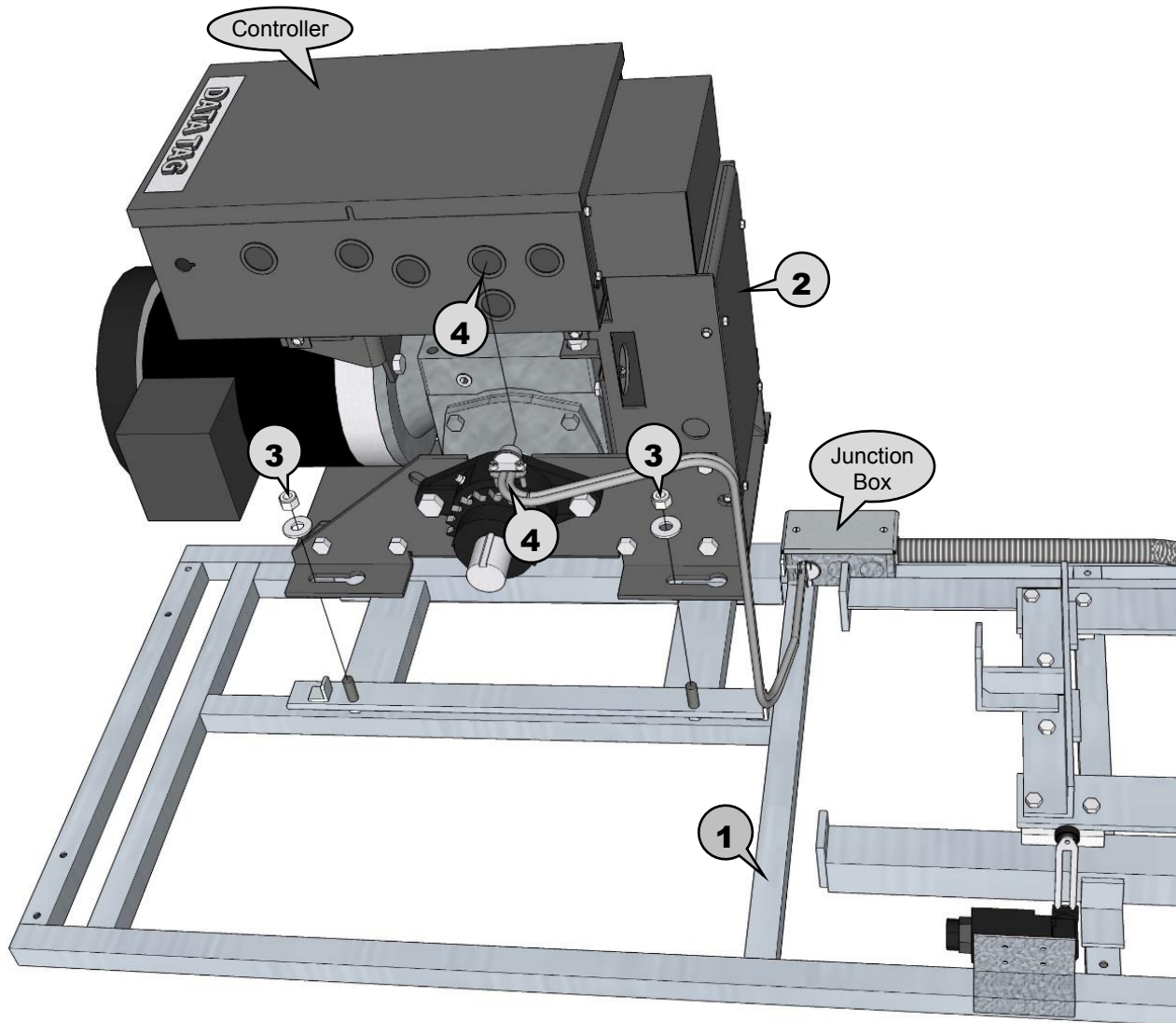
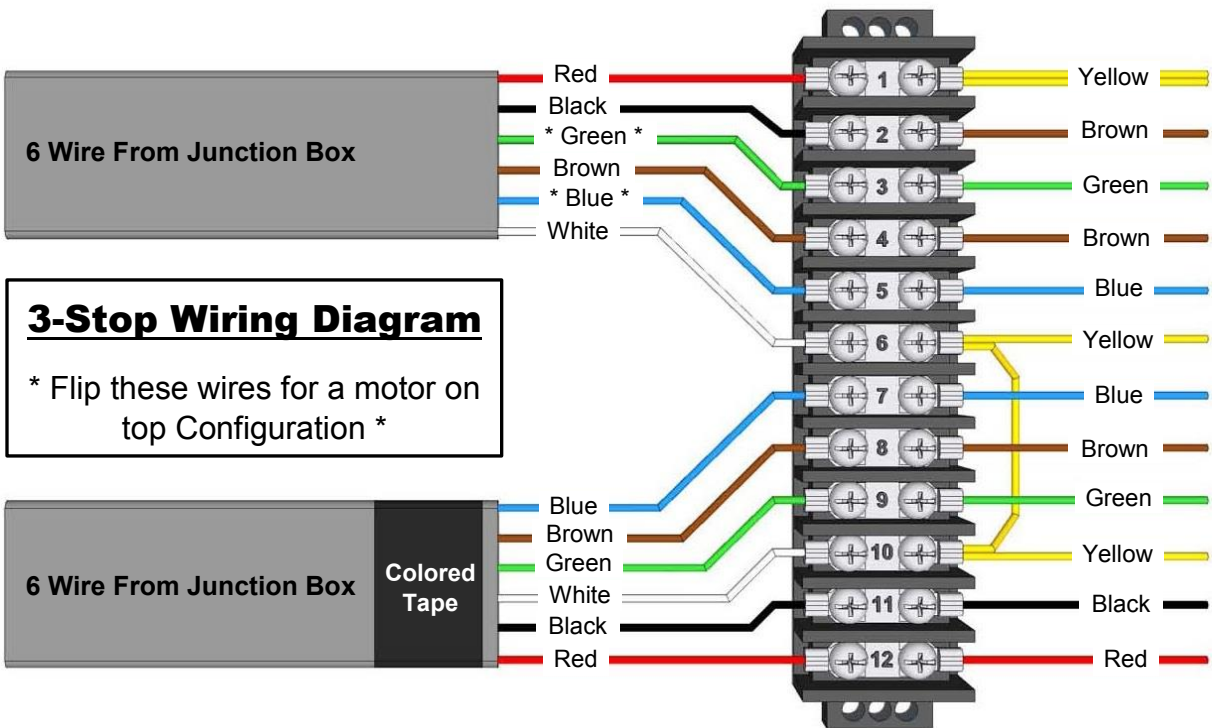
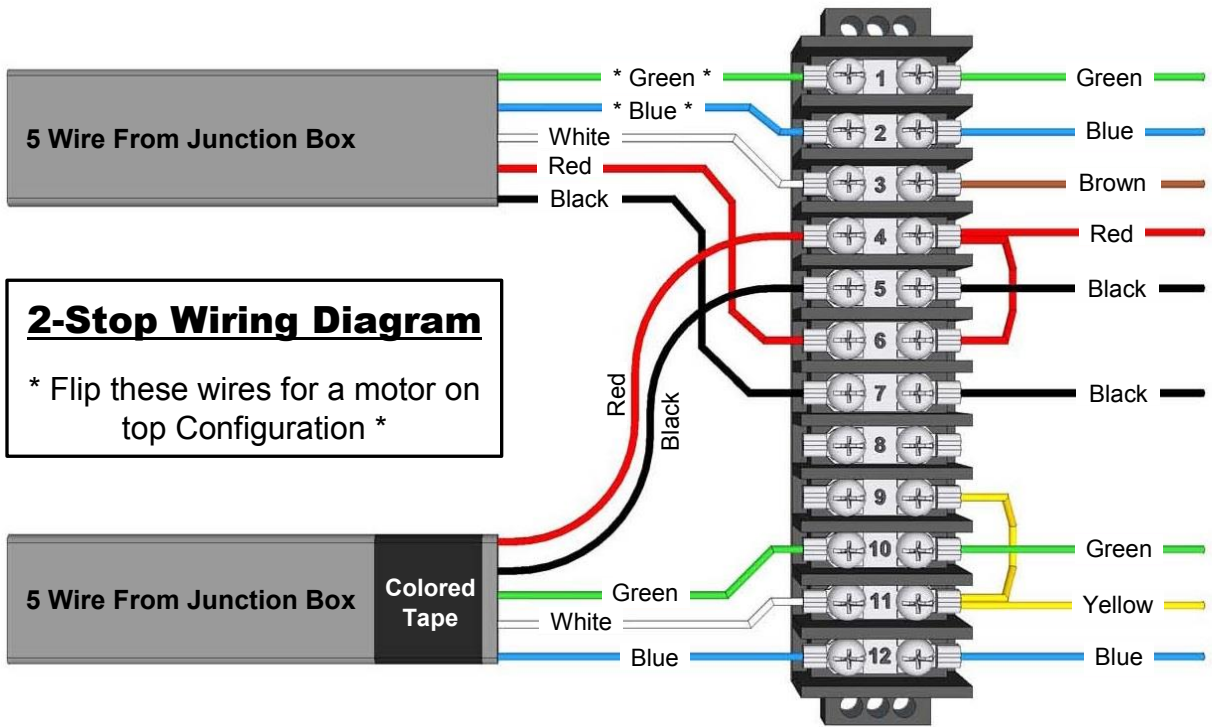

Figure 1

NOTE: For some motor on top configurations the chain is tied to the motor. When mounting a motor with chain, make sure the chain bundle is positioned down the track & rail in between track and not behind rail. (see Page 11, Figures 4 & 5, **9**)

PART 1b

Connecting Wires to T-bar in Controller



PART 2a

Track & Rail Installation

Motor on Bottom Configuration

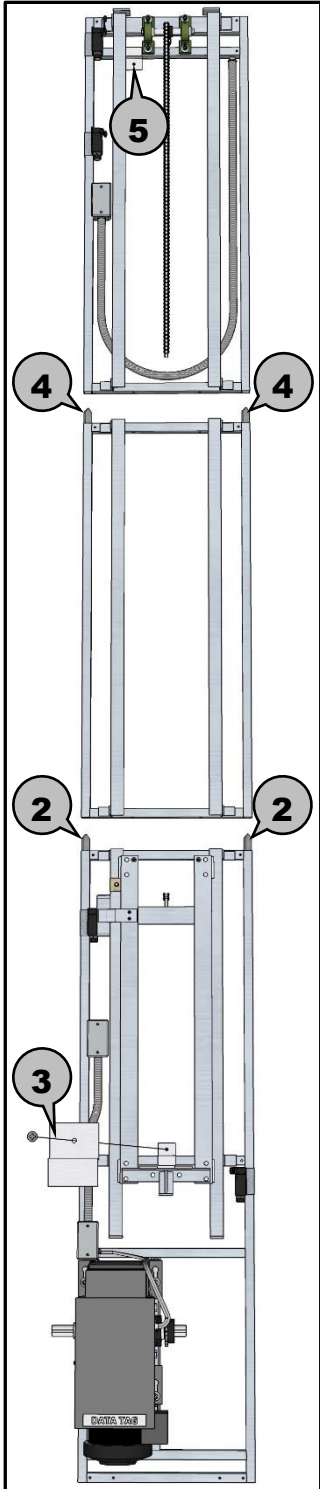

Figure 2

- 1** Before stacking the dumbwaiter into place, be sure that you have backing in or on the wall, as recommended (**see Page 7**), to which the track & rail assembly will be mounted.
- 2** Drop two (2) stacking pins into the top of the two outer vertical tubes of the bottom section, and position section centered against the mounting wall. (**see Figure 2**)
- 3** Use provided frame clip and 2" screw to temporarily hold section in place against the wall. Make sure screws go into solid wood. (**see Figure 2**)
- 4** Drop two (2) stacking pins into the top of the two outer vertical tubes of the next section, and position section on top of previous section using the stacking pins to guide it into place centered against the mounting wall. (**see Figure 2**)
- 5** Use provided frame clip and 2" screw to temporarily hold section in place against the wall. Make sure screws go into solid wood. (**see Figure 2**)
- 6** Use two (2) ¼" x 2 ¼" bolts & nuts to fasten sections together. (**see Figure 3**)
NOTE: Before tightening the bolts, be sure the tracks are in line and there is a smooth transition between the two sections.
- 7** Repeat steps 4 thru 6 for each additional section.
NOTE: After stacking the top section, make sure that it is centered on the mounting wall.
- 8** Use provided 3" lag screws to fasten track & rail assembly to wall. (**see Figure 3**)

NOTE: When fastening track & rail assembly to the wall, verify the track is centered on the mounting wall through the entire shaft and that there is a smooth transition between track sections. Overtightening the lag bolts can pull the track out of alignment. If necessary use shims between wall and frames to align tracks. For very small adjustments a crescent wrench can be used to bend track until aligned.

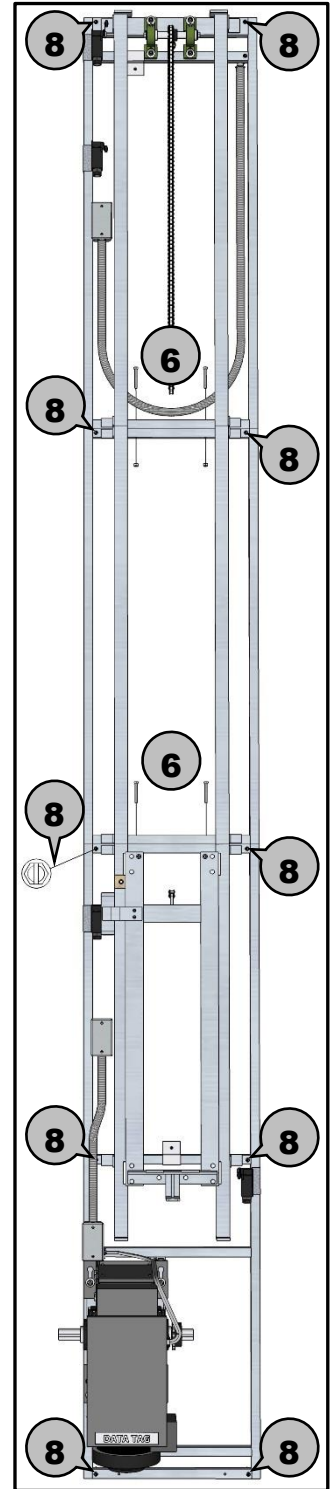

Figure 3

PART 2b

Track & Rail Installation

Motor on Top Configuration

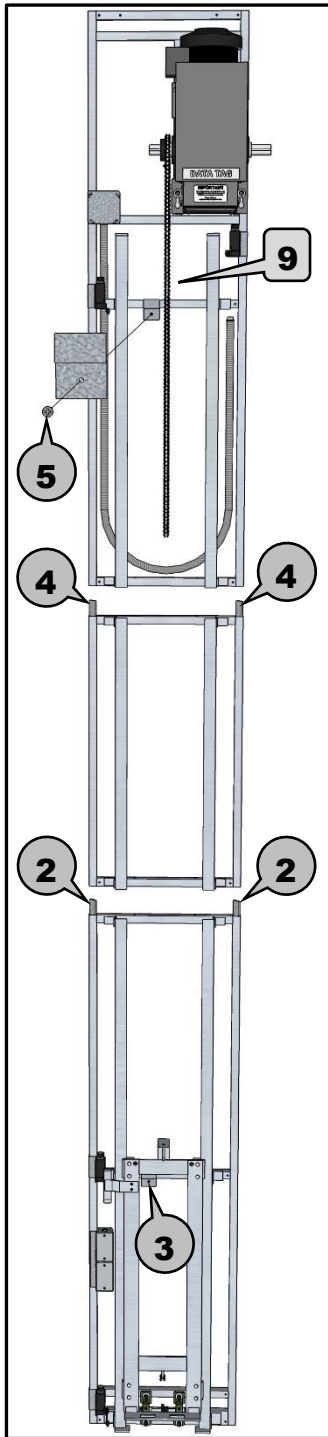

Figure 4

- 1** Before stacking the dumbwaiter into place, be sure that you have backing in or on the wall, as recommended (see Page 7), to which the track & rail assembly will be mounted.
- 2** Drop two (2) stacking pins into the top of the two outer vertical tubes of the bottom section, and position section centered against the mounting wall. (see Figure 4)
- 3** Use provided frame clip and 2" screw to temporarily hold section in place against the wall. Make sure screws go into solid wood. (see Figure 4)
- 4** Drop two (2) stacking pins into the top of the two outer vertical tubes of the next section, and position section on top of previous section using the stacking pins to guide it into place centered against the mounting wall. (see Figure 4)
- 5** Use provided frame clip and 2" screw to temporarily hold section in place against the wall. Make sure screws go into solid wood. (see Figure 4)
- 6** Use two (2) ¼" x 2 ¼" bolts & nuts to fasten sections together. (see Figure 5)
NOTE: Before tightening the bolts, be sure the tracks are in line and there is a smooth transition between the two sections.
- 7** Repeat steps 4 thru 6 for each additional section.
NOTE: After stacking the top section, make sure that it is centered on the mounting wall.
- 8** Use provided 3" lag screws to fasten track & rail assembly to wall. (see Figure 5)

NOTE: When fastening track & rail assembly to the wall, verify the track is centered on the mounting wall through the entire shaft and that there is a smooth transition between track sections. Overtightening the lag bolts can pull the track out of alignment. If necessary use shims between wall and frames to align tracks. For very small adjustments a crescent wrench can be used to bend track until aligned.

- 9** See Note at bottom of Page 8

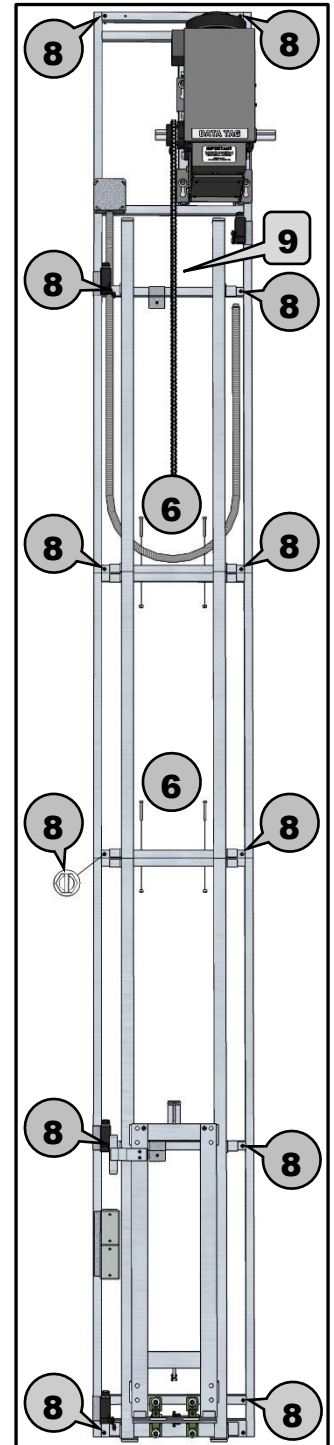

Figure 5

PART 3a

Gearbox Breather Installation

Motor on Bottom Configuration

⚠ WARNING ⚠

THE GEARBOX BREATHER PLUG MUST BE PROPERLY INSTALLED!!
FAILURE TO DO SO COULD DAMAGE THE MOTOR AND VOID THE WARRANTY.

Once the track & rail assembly is fastened securely to the wall, install the gearbox breather plug.

Note: The breather plug is shipped in a bag attached to a screw on the brake cover. (see Figure 6)

- 1** Remove the factory installed plug using either a 6mm Allen wrench or a 9/16" (14mm) socket. (see Figure 6)
- 2** Install breather plug hand tight or until the rubber "O" ring is seated snugly against the gear box. **Do not overtighten!** (see Figure 6)
- 3** Remove and discard red pin from breather plug.

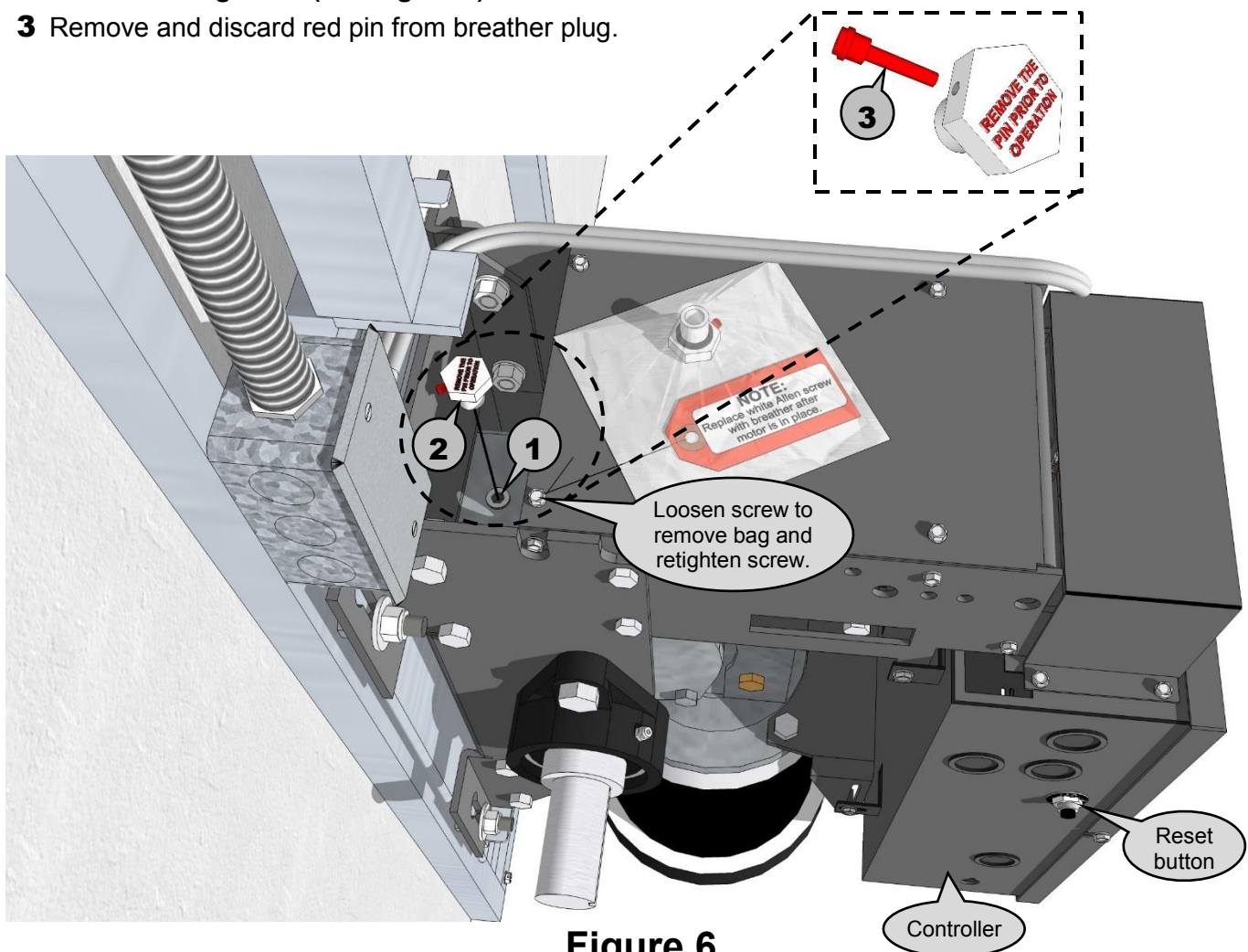

Figure 6

PART 3b

3 Phase Motor Rotation

Motor on Bottom Configuration

⚠ WARNING ⚠

THE ROTATION OF THE MOTOR MUST BE CHECKED BEFORE INSTALLING THE CHAIN!!
FAILURE TO DO SO COULD DAMAGE THE DUMBWAITER AND VOID THE WARRANTY.

- 1 Have your certified electrician connect power to the 3 terminal T-bar and ground wire to grounding block. (see Figure 7)
- 2 To check the motor rotation, open the control box and locate the Down "D" and Up "U" contactor. (see Figure 8)
- 3 Watch the rotation of the sprocket when the up contactor is pressed. If the direction of rotation is not the same direction as shown in Figure 9, go on to Step 4. If the direction of rotation is the same as shown in Figure 9, go on to Step 5.
- 4 Swap 2 of the 3 incoming power supply wires and go back to Step 2. (For example move the wire from L3 to L2 and the wire from L2 to L3.)
- 5 Turn power supply off at breaker or label each power supply wire so that they may be disconnected from the T-bar and reconnected later to the correct terminal, then disconnect the three power supply wires from the T-bar.

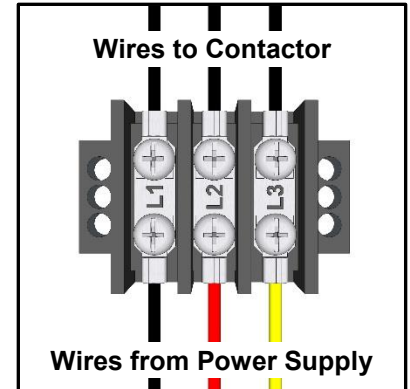

Figure 7

⚠ WARNING ⚠

A.C. POWER MUST BE TURNED OFF OR DISCONNECTED BEFORE CHAIN INSTALLATION! FAILURE TO DO SO COULD DAMAGE THE DUMBWAITER AND/OR CAUSE SERIOUS BODILY INJURY, LOSS OF LIMB, OR DEATH!

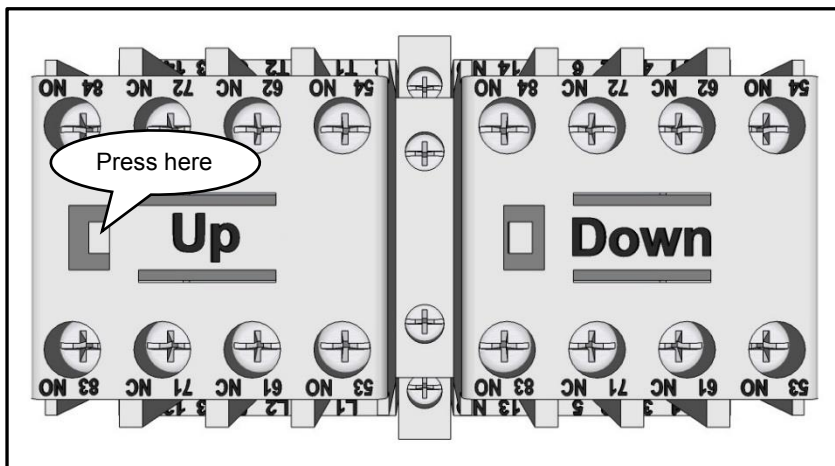

Figure 8

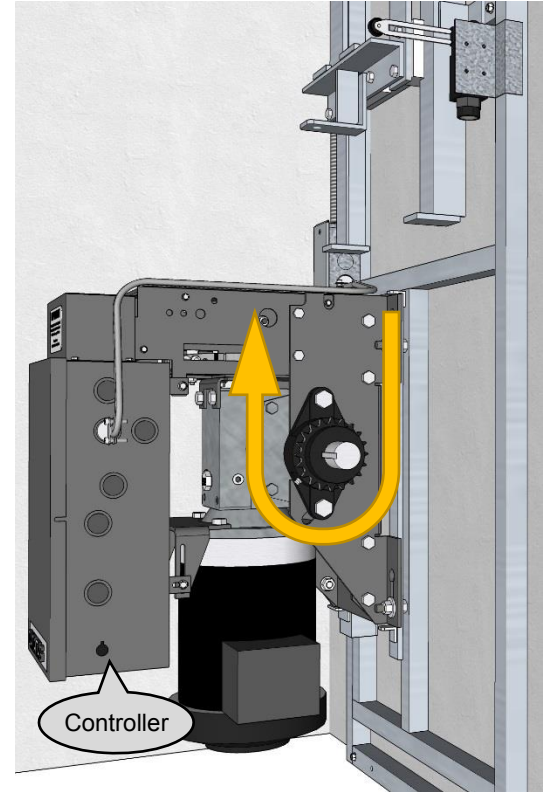

Figure 9

PART 3c

Chain Installation

Motor on Bottom Configuration

⚠ WARNING ⚠

NEVER INSTALL CHAIN UNLESS A.C. POWER IS DISCONNECTED FROM DUMBWAITER! FAILURE TO DO SO COULD DAMAGE THE DUMBWAITER AND/OR CAUSE SERIOUS BODILY INJURY, LOSS OF LIMB, OR DEATH!

- 1** The chain is bundled and tied to the top track & rail section. Only cut the **white** plastic ties holding the chain to the track.
- 2** Cut the **white** plastic ties holding chain to the pillow block shaft, one at a time, in the order they are labeled and carefully lower the chain to prevent tangling.

NOTE: Do not cut the black plastic tie! (see Figure 10)

- 3** Cut any remaining **white** plastic ties.
- 4** Use provided master link, attached near the top of the trolley with a plastic tie, to connect chain to top end of trolley. (see Figure 11)

⚠ WARNING ⚠

MAKE SURE THAT THE MASTER LINK IS FASTENED SECURELY! FAILURE TO DO SO COULD DAMAGE THE DUMBWAITER AND/OR CAUSE SERIOUS BODILY INJURY, LOSS OF LIMB, OR DEATH!

- 5** The other end of the chain should hang down behind the trolley and be placed around the drive sprocket of the motor. Then insert the threaded adjusting bolt, on the end of the chain, into the hole on the bottom of the trolley, where the adjusting nut is tied on, and use the adjusting nut to secure the adjusting bolt to the trolley. Use a blade screwdriver or needle nose pliers to hold chain from twisting and tighten adjusting nut until Nyloc nut is tightly seated against trolley. **Do not adjust Nyloc!** (see Figure 12)

NOTE: If the adjusting bolt won't reach, remove trolley stop. (see Figure 11)

⚠ WARNING ⚠

MAKE SURE THAT THE CHAIN IS COMPLETELY SEATED ON THE DRIVE SPROCKET! FAILURE TO DO SO COULD DAMAGE THE DUMBWAITER AND/OR CAUSE SERIOUS BODILY INJURY, LOSS OF LIMB, OR DEATH!

- 6** Some machines will have a trolley stop screwed to the track for shipping purposes, and it should be removed at this time. (see Figure 11)
- 7** Cut black plastic tie off. (see Figure 10)

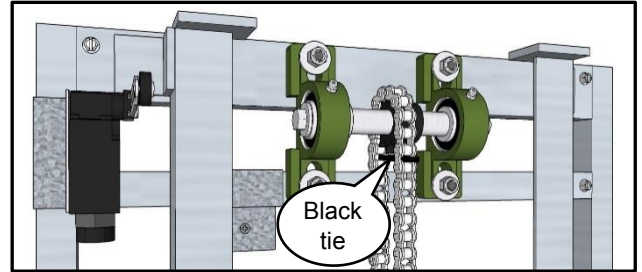

Figure 10

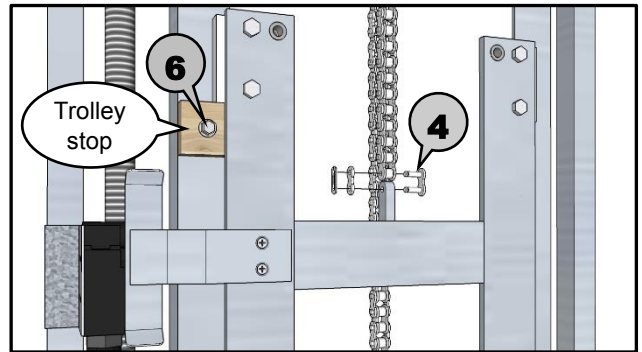

Figure 11

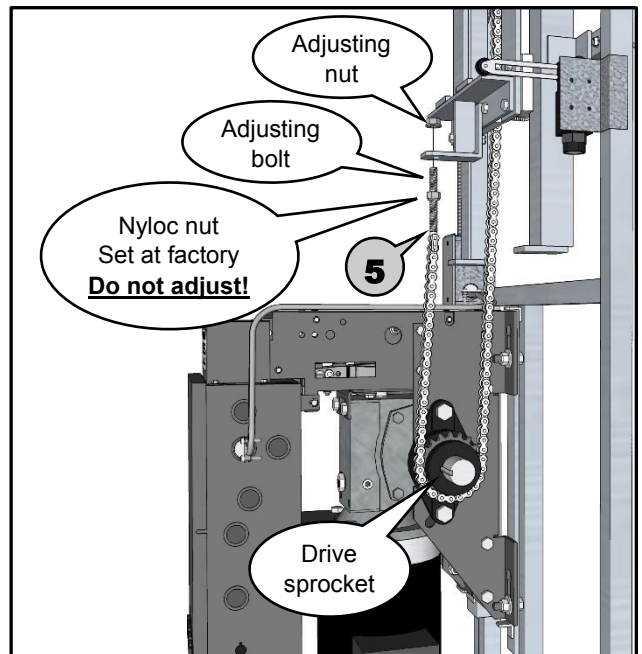

Figure 12

PART 3d

Gearbox Breather Installation

Motor on Top Configuration

⚠ WARNING ⚠

THE GEARBOX BREATHER PLUG MUST BE PROPERLY INSTALLED!!
FAILURE TO DO SO COULD DAMAGE THE MOTOR AND VOID THE WARRANTY.

- 1 Once the track & rail assembly is fastened securely to the wall, remove and discard red pin.
(see Figure 13)

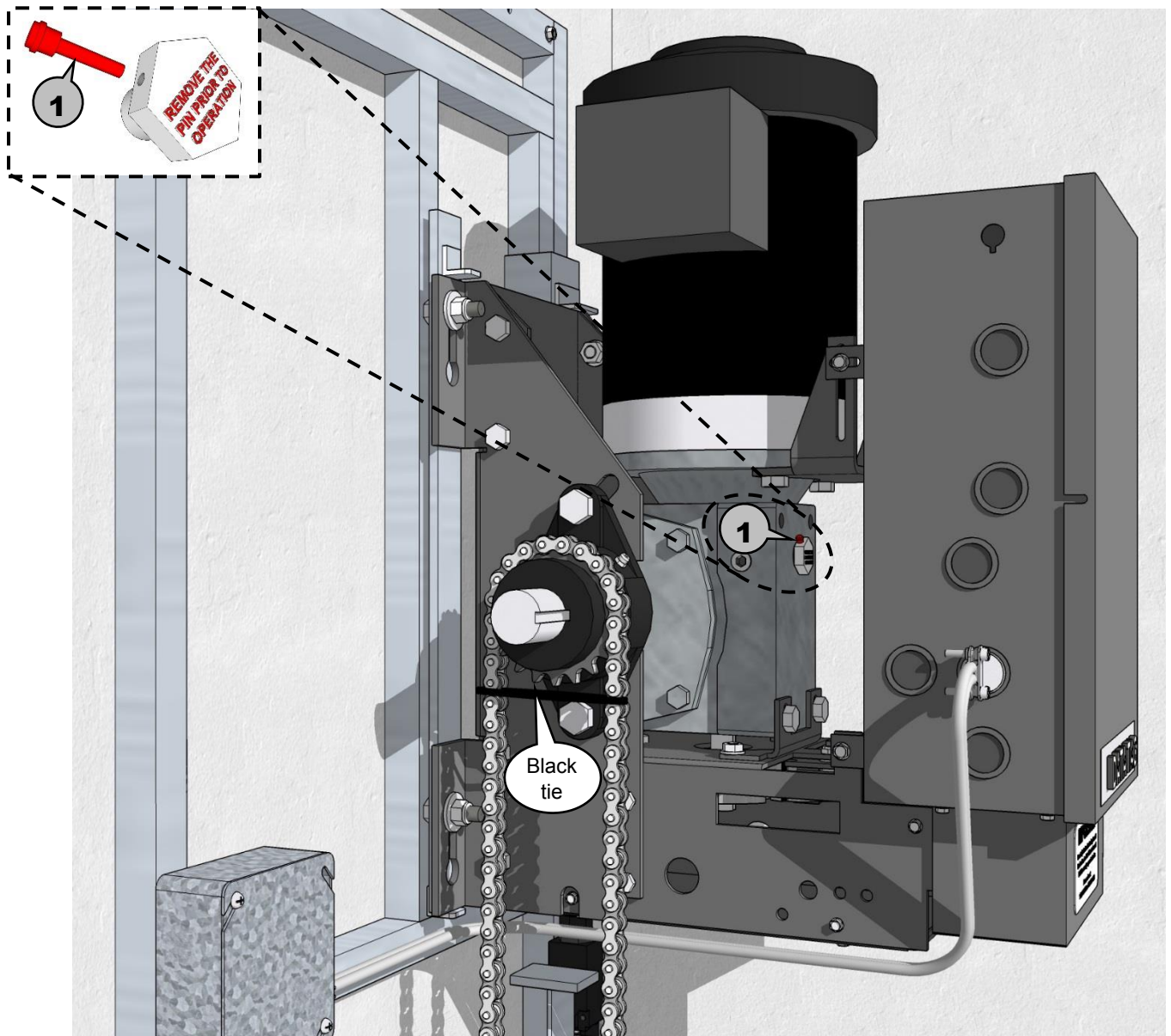

Figure 13

www.dumbwaiters.com

1-800-409-5438

PART 3e

3 Phase Motor Rotation

Motor on Top Configuration

⚠ WARNING ⚠

THE ROTATION OF THE MOTOR MUST BE CHECKED BEFORE INSTALLING THE CHAIN!!
FAILURE TO DO SO COULD DAMAGE THE DUMBWAITER AND VOID THE WARRANTY.

- 1** Have your certified electrician connect power to the 3 terminal T-bar and ground wire to grounding block. (see Figure 14)
- 2** To check the motor rotation, open the control box and locate the Down "D" and Up "U" contactor. (see Figure 15)
- 3** Watch the rotation of the sprocket when the up contactor is pressed. If the direction of rotation is not the same direction as shown in **Figure 16**, go on to **Step 4**. If the direction of rotation is the same as shown in **Figure 16**, go on to **Step 5**.
- 4** Swap 2 of the 3 incoming power supply wires and go back to **Step 2**. (For example move the wire from L3 to L2 and the wire from L2 to L3.)
- 5** Turn power supply off at breaker or label each power supply wire so that they may be disconnected from the T-bar and reconnected later to the correct terminal, then disconnect the three power supply wires from the T-bar.

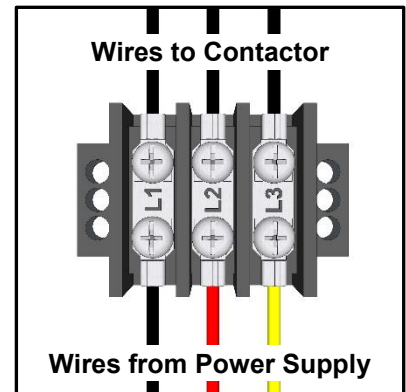

Figure 14

⚠ WARNING ⚠

A.C. POWER MUST BE TURNED OFF OR DISCONNECTED BEFORE CHAIN
INSTALLATION! FAILURE TO DO SO COULD DAMAGE THE DUMBWAITER
AND/OR CAUSE SERIOUS BODILY INJURY, LOSS OF LIMB, OR DEATH!

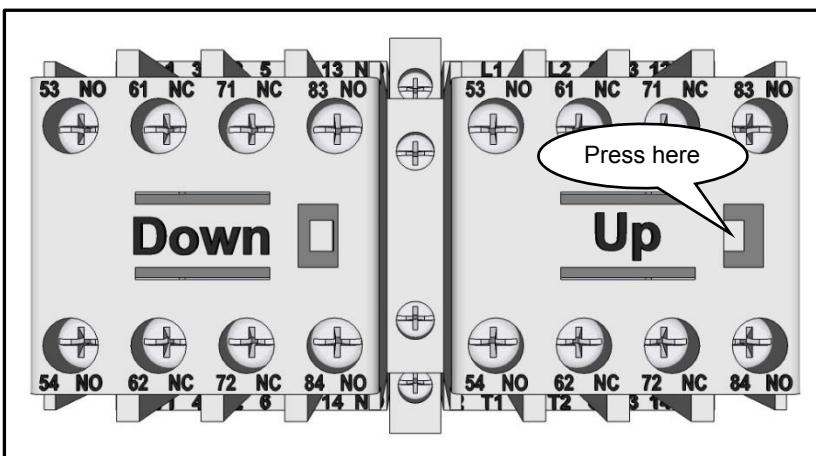

Figure 15

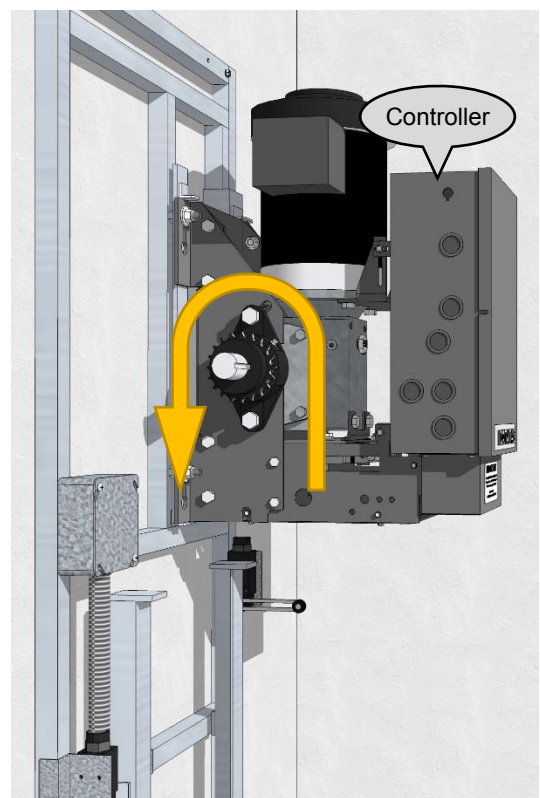

Figure 16

PART 3f

Chain Installation

Motor on Top Configuration

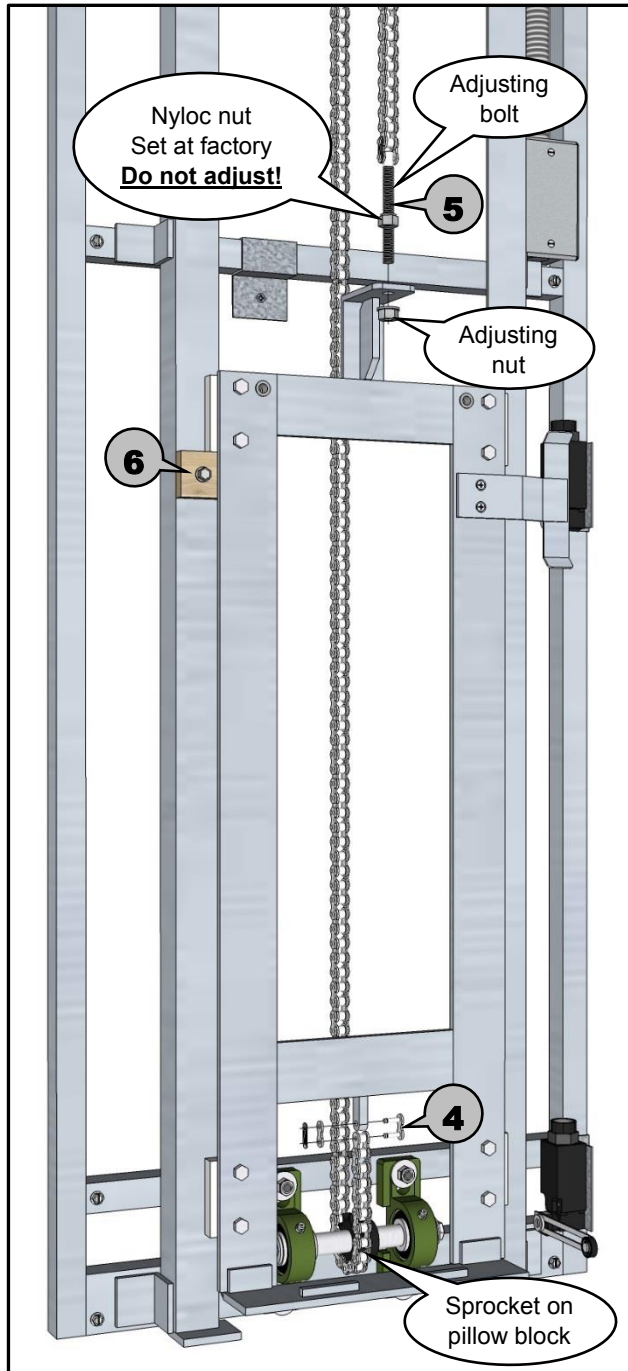

Figure 17

⚠ WARNING ⚠

NEVER INSTALL CHAIN UNLESS A.C. POWER IS DISCONNECTED FROM DUMBWAITER! FAILURE TO DO SO COULD DAMAGE THE DUMBWAITER AND/OR CAUSE SERIOUS BODILY INJURY, LOSS OF LIMB, OR DEATH!

- 1 If the chain is bundled and tied to the motor. Only cut the **white** plastic ties holding the chain bundle to the motor.
- 2 Cut the **white** plastic ties holding the chain to the motor shaft, one at a time, in the order they are labeled and carefully lower the chain to prevent tangling.
NOTE: Do not cut the black plastic tie!
(see Page 15, Figure 13)
- 3 Cut any remaining **white** plastic ties.
- 4 One end of the chain should hang down behind the trolley and be placed around sprocket on the pillow block. Then use provided master link, attached near the bottom of the trolley with a plastic tie, to connect chain to bottom end of trolley. (see Figure 17)

⚠ WARNING ⚠

MAKE SURE THAT THE MASTER LINK IS FASTENED SECURELY! FAILURE TO DO SO COULD DAMAGE THE DUMBWAITER AND/OR CAUSE SERIOUS BODILY INJURY, LOSS OF LIMB, OR DEATH!

- 5 The other end of the chain with the adjusting bolt should hang down near the top of the trolley. Insert the threaded adjusting bolt, on the end of the chain, into the hole on the top of the trolley where the adjusting nut is tied on, and use the adjusting nut to secure the adjusting bolt to the trolley. Use a blade screwdriver or needle nose pliers to hold chain from twisting and tighten adjusting nut until Nyloc nut is tightly seated against trolley. **Do not adjust Nyloc!** (see Figure 17)
- 6 Some machines will have a trolley stop screwed to the track for shipping purposes, and it should be removed at this time. (see Figure 17)
- 7 Cut black plastic tie off. (see Page 15, Figure 13)

PART 4

Wiring Track & Rail Assembly

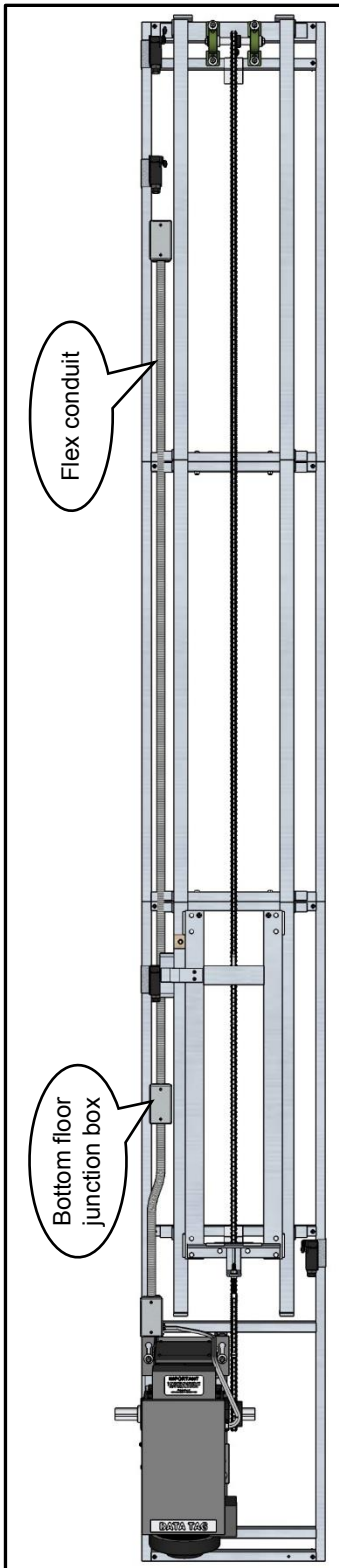

Figure 18

⚠ WARNING ⚠

**MAKE SURE A.C. POWER IS DISCONNECTED FROM DUMBWAITER!!
FAILURE TO DO SO COULD DAMAGE THE DUMBWAITER AND/OR CAUSE
SERIOUS BODILY INJURY, LOSS OF LIMB, OR DEATH!**

- Lower flex conduit from top floor and connect to junction box at bottom floor. (see Figures 18 & 19)

NOTE: Check female connectors for metal shavings and clean them out if necessary.

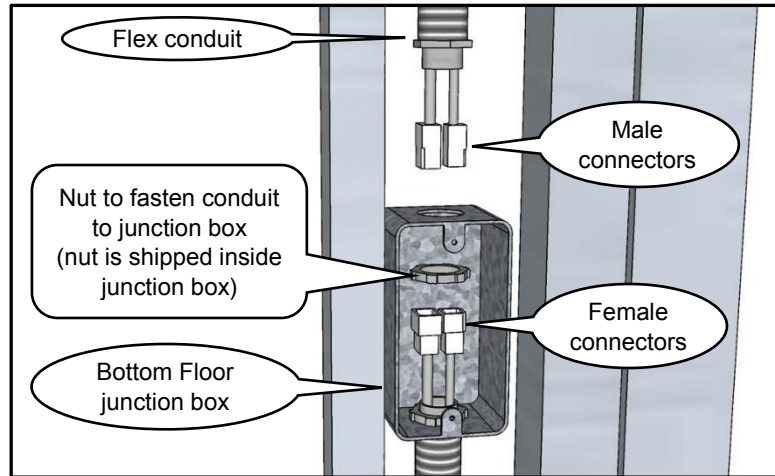

Figure 19

- On 2-stop dumbwaiters, one set of wires has female connectors and the other set has male connectors. Match up each male and female connector and seat them firmly together. (see Figure 20)

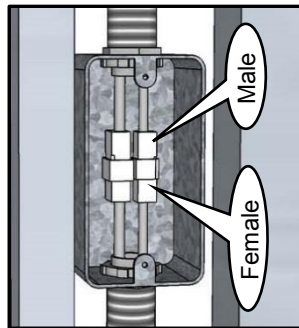

Figure 20

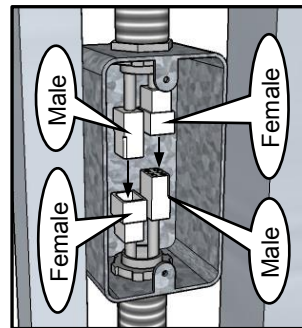

Figure 21

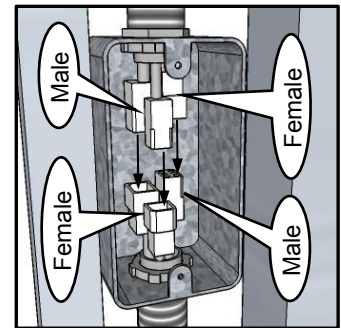

Figure 22

- On 3-stop dumbwaiters, the wires dropping down will have a male and female connector as will the junction box. Make sure the male and female from above plug into the male and female from below. (for 3-stops see Figure 21) (for 4-stops see Figure 22)

PART 5

Rough Framing & Call/Send Wiring Rough in

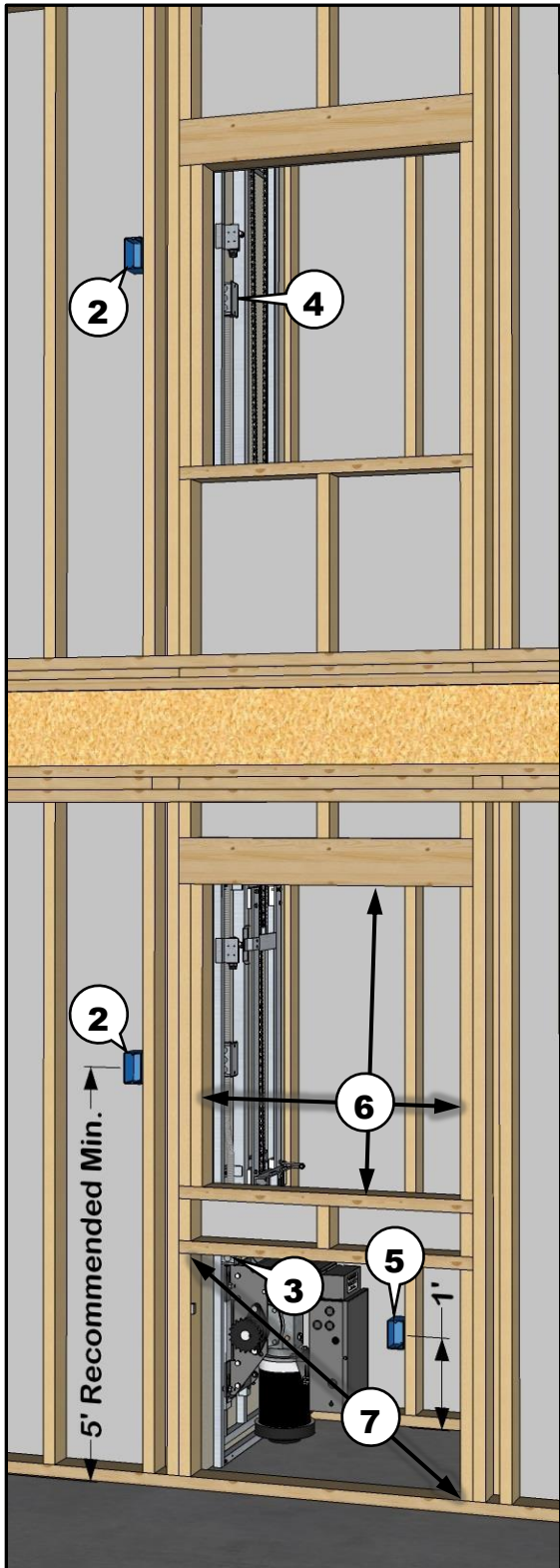

Figure 23

⚠ WARNING ⚠

MAKE SURE A.C. POWER IS DISCONNECTED FROM DUMBWAITER!!
FAILURE TO DO SO COULD DAMAGE THE DUMBWAITER AND/OR
CAUSE SERIOUS BODILY INJURY, LOSS OF LIMB, OR DEATH!

- 1 Use standard framing to construct hoistway (dumbwaiter shaft). (see Page 7 for wall backing)
NOTE: It is the responsibility of the contractor to build the hoistway (dumbwaiter shaft) according to your local codes and regulations.
- 2 Place push button boxes per owner's instruction, making sure there is enough wire to reach the box. (see Figure 23)

⚠ WARNING ⚠

INSTALL PUSH BUTTONS OUT OF REACH OF CHILDREN AT A RECOMMENDED MINIMUM HEIGHT OF 5 FEET (1.5 M), AND IN A LOCATION TO PREVENT UNINTENTIONAL ACTIVATION. FAILURE TO DO SO COULD DAMAGE THE DUMBWAITER AND/OR CAUSE SERIOUS BODILY INJURY, LOSS OF LIMB, OR DEATH!

- 3 Rough-in wire for push buttons from junction box to bottom floor push button box. (see Figure 23)
- 4 Rough-in wire for push buttons from top floor junction box to top floor push button box. (see Figure 23)
- 5 Install power supply junction box 12 inches (0.3 m) above floor on wall adjacent to mounting wall. (see Figure 23) (see Page 5, # 11 for voltage requirements)
NOTE: Do not install junction box on wall where track & rail is to be mounted!
- 6 The first floor finished jam should be larger than the dumbwaiter car for installation or removal of car for servicing.

⚠ IMPORTANT ⚠

A CAR 30" w X 30" d X 36" h NEEDS ONE "FINISHED" OPENING TO MEASURE 31" w X 37" h FOR INSTALLING THE CAR AND FOR REMOVAL OF THE CAR TO SERVICE THE DUMBWAITER SAFELY.

- 7 Removable access panel or door for servicing motor, brake, clutch, or car adjustment. (see Figure 23)

⚠ IMPORTANT ⚠

CODE REQUIRES ALL DUMBWAITERS TO HAVE A MOTOR ACCESS PANEL OR A LOCKABLE DOOR TO SERVICE THE DUMBWAITER SAFELY.

PART 6a

Finish Wiring

Call/Send Push Buttons & Options

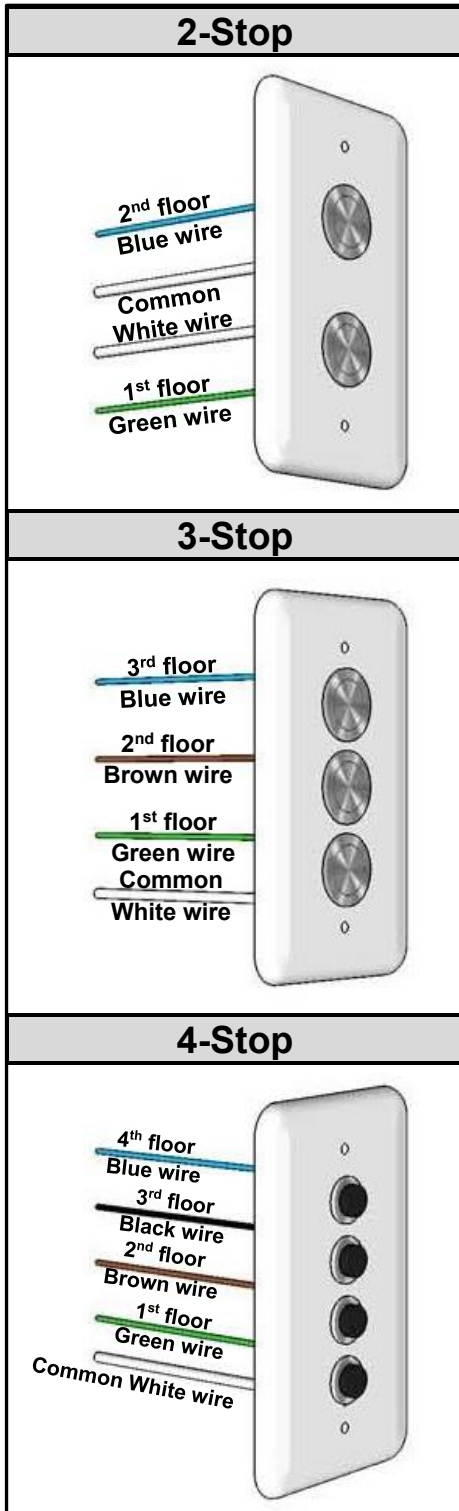

Figure 24

⚠ WARNING ⚠

MAKE SURE A.C. POWER IS DISCONNECTED FROM DUMBWAITER!! FAILURE TO DO SO COULD DAMAGE THE DUMBWAITER AND/OR CAUSE SERIOUS BODILY INJURY, LOSS OF LIMB, OR DEATH!

- 1** To wire in push buttons and options; match same color wires from box in wall and push buttons, together, and twist on provided wire nuts. (i.e., blue to blue, green to green, etc.)
- 2** Secure wire nut connections with electrical tape.
- 3** Use provided screws to screw push button wall plate to box in wall.

Push Button Options

If you ordered the “keyed on/off lock”, “emergency stop button” or the “car here light”, you will have additional wires to secure as described below.

- The car here lights always have red and black wires.
- The keyed lock or emergency stop button without the car here lights will have a red and black wire.
- The keyed lock or emergency stop button with the car here lights, will have an orange and yellow wire.

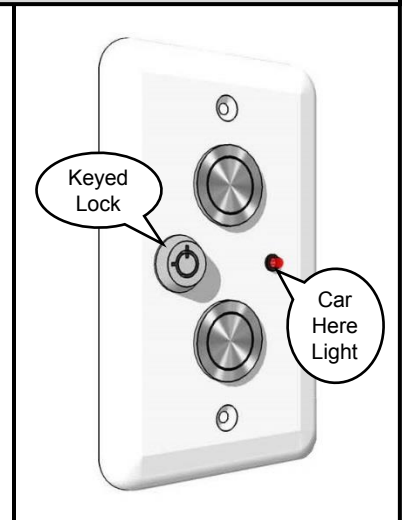

Figure 25

NOTE:

4-stop machines will have a separate 2 conductor wire for two options. The separate conductor is labeled accordingly.

Emergency Stop - (Figure 26)

- The emergency stop button is wired on the normally closed side.
- To release the emergency stop button rotate the red button clockwise a quarter turn (90°), or until red button pops out.

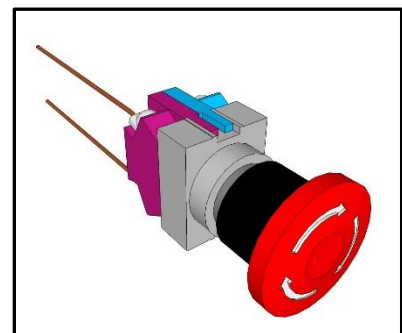

Figure 26

PART 6b

Finish Wiring

Door Interlock Installation

⚠ WARNING ⚠

MAKE SURE A.C. POWER IS DISCONNECTED FROM DUMBWAITER!!
FAILURE TO DO SO COULD DAMAGE THE DUMBWAITER AND/OR CAUSE
SERIOUS BODILY INJURY, LOSS OF LIMB, OR DEATH!

⚠ IMPORTANT ⚠

RDI DOOR INTERLOCK MUST BE MOUNTED TO THE SIDE JAMB!
RDI DOOR INTERLOCKS CAN NOT BE MOUNTED HORIZONTALLY!
AN "RDI-G-R" INTERLOCK MOUNTS TO THE TOP RIGHT SIDE OF THE JAMB.
AN "RDI-G-L" INTERLOCK MOUNTS TO THE TOP LEFT SIDE OF THE JAMB.

Note: For installation of RDI door interlocks, use template included with interlocks. If the template has been misplaced, an extra template has been included at the end of these instructions. The interlocks can be adjusted for left hand or right hand mount. Watch our video on YouTube for switching an interlock from right hand to left hand mount. <https://youtu.be/u5wg3gLffbY>

- 1 Fold template 90° on fold line and place in corner of door and jamb.
- 2 Center punch holes for temporary mounting of interlock on jamb.
- 3 Center punch holes for mounting catch on door.
- 4 Center punch hole for emergency override switch access on door.
- 5 Predrill temporary mounting holes and catch mounting holes with appropriately sized bit.
- 6 Drill 5/8" hole for emergency override switch access.
- 7 Mount interlock to jamb using temporary mounting holes. Mount catch to door.
- 8 Adjust interlock to receive door catch properly then add 4 corner screws to hold interlock to jamb.

Mounted Left Hand RDI

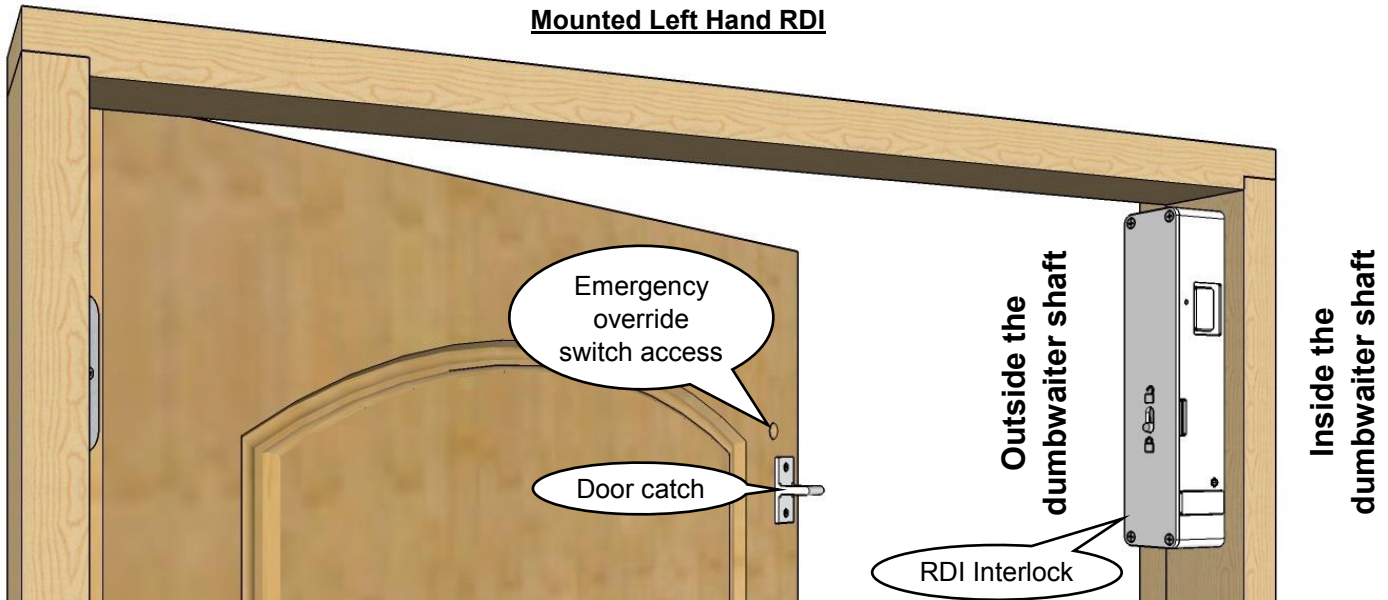

Figure 27

www.dumbwaiters.com

1-800-409-5438

PART 6c

Finish Wiring

Door Interlocks & Safety Switch

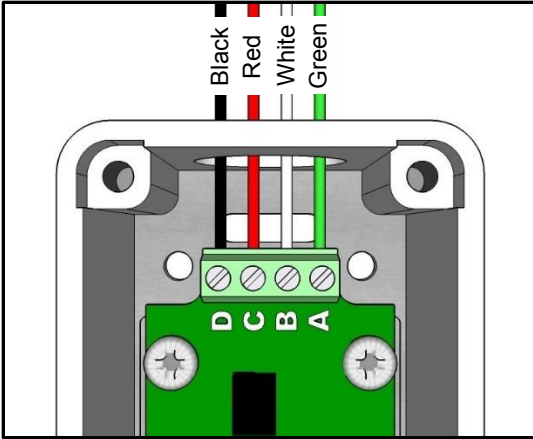

Figure 28

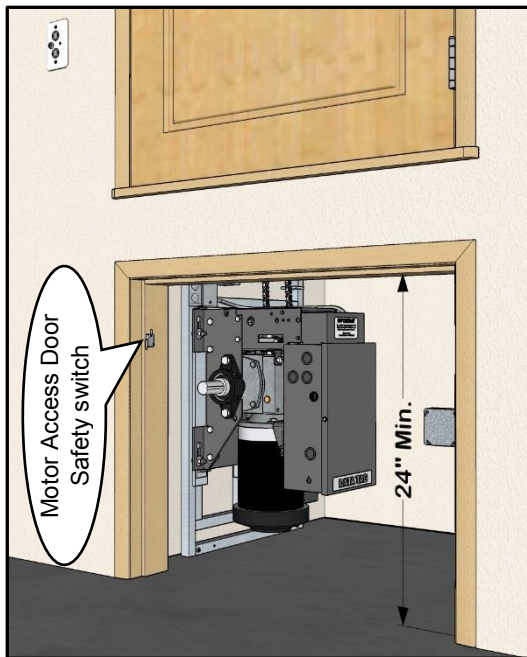

Figure 29

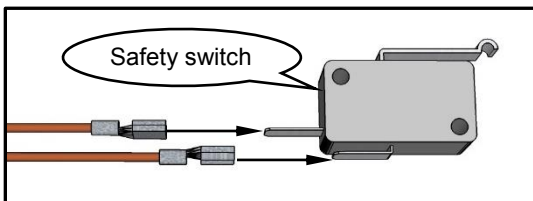

Figure 30

⚠ WARNING ⚠

MAKE SURE A.C. POWER IS DISCONNECTED FROM DUMBWAITER!!
FAILURE TO DO SO COULD DAMAGE THE DUMBWAITER AND/OR
CAUSE SERIOUS BODILY INJURY, LOSS OF LIMB, OR DEATH!

- 1** The RDI door interlocks must be mounted vertically and opposite the hinges. (see Page 21, Figure 27)
- 2** In the 4 wire safety circuit from junction box near each opening is a black, red, white, and green wire. Connect the 4 wires to the terminal block in the RDI interlock at the first opening. (see Figure 28)
 - Connect the black wire to the “D” terminal.
 - Connect the red wire to the “C” terminal.
 - Connect the white wire to the “B” terminal.
 - Connect the green wire to the “A” terminal.
- 3** Reconnect power supply and test interlock operation.
- 4** Disconnect power supply and repeat **Steps 2 & 3** for each additional opening. Once all interlocks are wired in and working, the A.C. power supply can stay connected.
- 5** Mount the safety switch to the jam of the access panel opening, so that you can hear the switch click when opening and closing the access door. (see Figure 29)

⚠ IMPORTANT ⚠

CODE REQUIRES ALL DUMBWAITERS TO HAVE A MOTOR ACCESS
PANEL OR DOOR TO SERVICE THE DUMBWAITER SAFELY.
THE MOTOR ACCESS PANEL OR DOOR MUST HAVE A SAFETY SWITCH.
FAILURE TO INSTALL A SAFETY SWITCH COULD CAUSE SERIOUS
BODILY INJURY, LOSS OF LIMB, OR DEATH, AND MAY VOID YOUR
WARRANTY

- 6** Connect “red” and “black” wires to door safety switch using the provided spade quick connectors. It does not matter which terminal the “red” and “black” wires are connected to. (see Figure 30)

⚠ IMPORTANT ⚠

SECURE WIRES DOWN TO JAM AND OR WALL TO PREVENT MOVING
DUMBWAITER CAR FROM SNAGGING ON WIRES AND DAMAGING
DUMBWAITER OR STRUCTURE.

PART 7

Installing the Dumbwaiter Car

⚠ WARNING ⚠

DO NOT INSTALL DUMBWAITER CAR UNTIL PUSH BUTTONS AND DOOR SAFETY SWITCHES ARE PROPERLY INSTALLED, AND ALL ADJUSTMENTS ARE COMPLETE!!
FAILURE TO DO SO COULD DAMAGE THE DUMBWAITER AND/OR CAUSE SERIOUS BODILY INJURY, LOSS OF LIMB, OR DEATH!

⚠ WARNING ⚠

MAKE SURE A.C. POWER IS DISCONNECTED FROM DUMBWAITER!! FAILURE TO DO SO COULD DAMAGE THE DUMBWAITER AND/OR CAUSE SERIOUS BODILY INJURY, LOSS OF LIMB, OR DEATH!

- 1** Removal of the RDI door interlock is necessary to install the dumbwaiter car.
- 2** Use provided bolts ($\frac{1}{4}$ "-20 x $1\frac{3}{4}$ ") & washers to secure dumbwaiter car to trolley. (see **Figure 31**)
- 3** When positioning car on trolley, make sure the tabs are hooked under car as shown in **Figure 32**.
- 4** Reinstall the RDI door interlock.

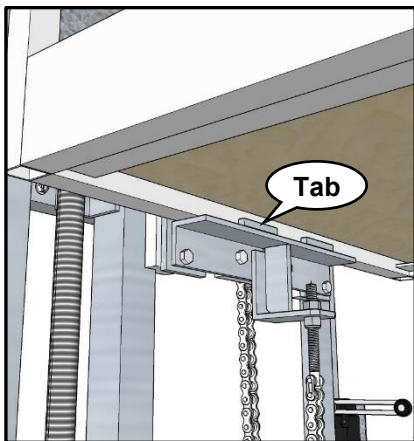

Figure 32

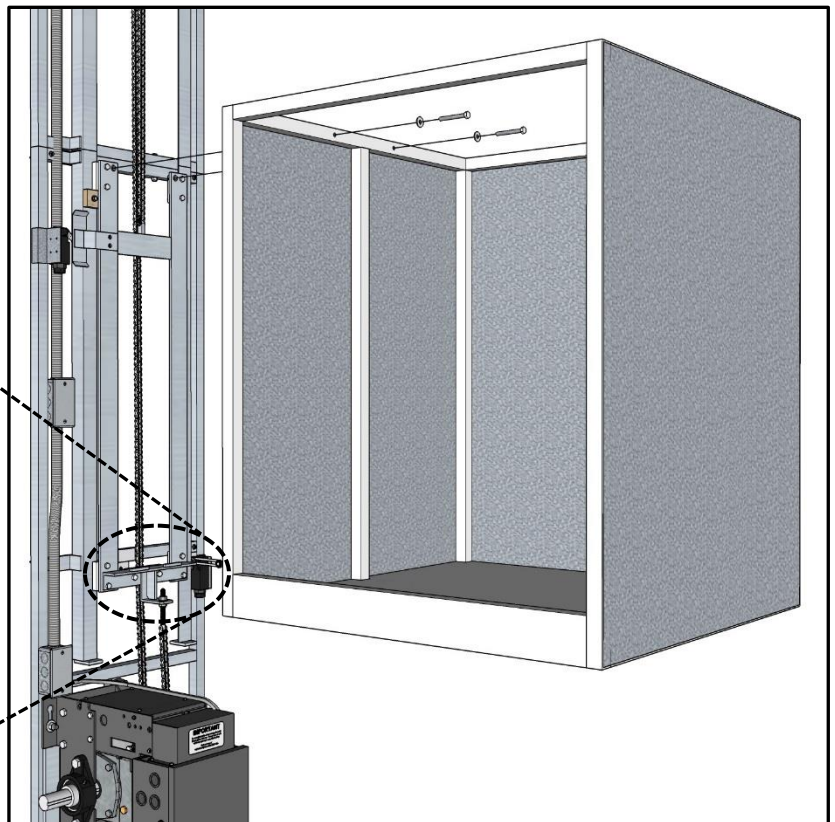

Figure 31

Troubleshooting

The following instructions refer to the wiring diagrams on:

Page 25 -- for 2-stop single phase machines
Page 26 -- for 2-stop three phase machines
Page 29 -- for 3-stop single phase machines

Page 30 -- for 3-stop three phase machines
Page 31 -- for 4-stop single phase machines
Page 32 -- for 4-stop three phase machines

1 Verify that the dumbwaiter has a.c. power.

- A. Check the circuit breaker to see if it has been tripped and reset breaker.
- B. Check the overload "Reset" button, on the side of the controller box, to see if it has popped out and reset it, if necessary, by pushing it back in.
(for "Reset" location on single phase P-300 see Page 12, Figure 6)
(the "Reset" on three phase P-300 is inside the controller)

2 Check for 24 volts a.c. in control box.

- A. Use a volt meter to test the low voltage side of the transformer. Connecting volt meter leads to the brown and yellow wires should show at least 24V a.c.
- B. Check lighted relays 1 & 2 to see if both relays are lit.
 - I. If relay 2 is lit and relay 1 is not, go on to step 3.
 - II. If both are out, check the 2 amp fuse mounted inside the control box on the side. It is best to remove the fuse and check for burn marks. Replace if blown.

3 Test the safety circuit.

- A. On terminal bar, for 2 stop machines, short out terminals 6 and 7. For 3 and 4 stop machines, short out terminals 1 and 2.
 - I. If relay 1 clicks, the safety circuit is not complete, go on to step 4.
 - II. If relay 1 is lit and does not click, check the connections to the push buttons.

4 Manually moving dumbwaiter car.

- A. Verify all doors are closed and the dumbwaiter car is not lower than the bottom floor opening or higher than the top floor opening.
 - I. If the dumbwaiter car is not vertically out of alignment and still does not function, please call Powerlift Dumbwaiters, Inc.
 - II. If the dumbwaiter car is vertically out of alignment, use the "UP" contactor to adjust the car up or use the "DOWN" contactor to adjust the car down.

⚠ WARNING ⚠

USING THE CONTACTORS TO MOVE THE DUMBWAITER CAR BYPASSES THE ENTIRE SAFETY CIRCUIT. HOLDING THE CONTACTOR IN COULD DAMAGE THE LIFT AND/OR CAUSE SERIOUS BODILY INJURY, LOSS OF LIMB, OR DEATH!

Contactor operation

- With 2 stop machines, the contactor will stay in when pressed and the dumbwaiter car will automatically go to the nearest floor when working properly. If the contactor does not stay in, there is a low voltage problem. Please call Powerlift Dumbwaiters, Inc.
- With 3 & 4 stop machines, the contactor will never stay in. If power is lost while the dumbwaiter car is between stops, the contactors will work like a momentary contact switch, and may be used to bump the car up or down to the nearest floor. Once the car is aligned with an opening, the pc board will be reset and the dumbwaiter should function properly.

Troubleshooting Controller Wiring Diagram 2-Stop / Single Phase

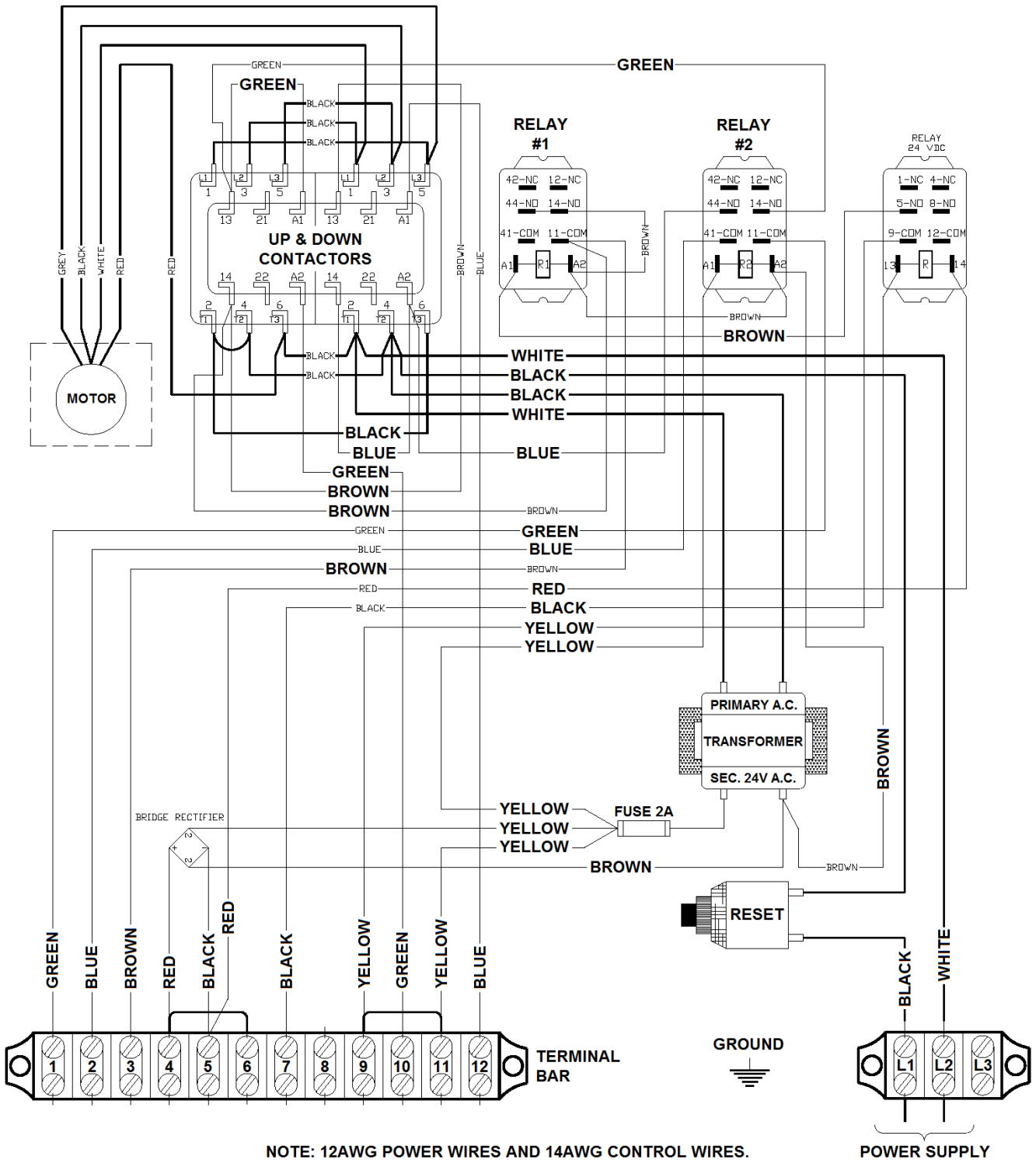

Troubleshooting Controller Wiring Diagram 2-Stop / Three Phase

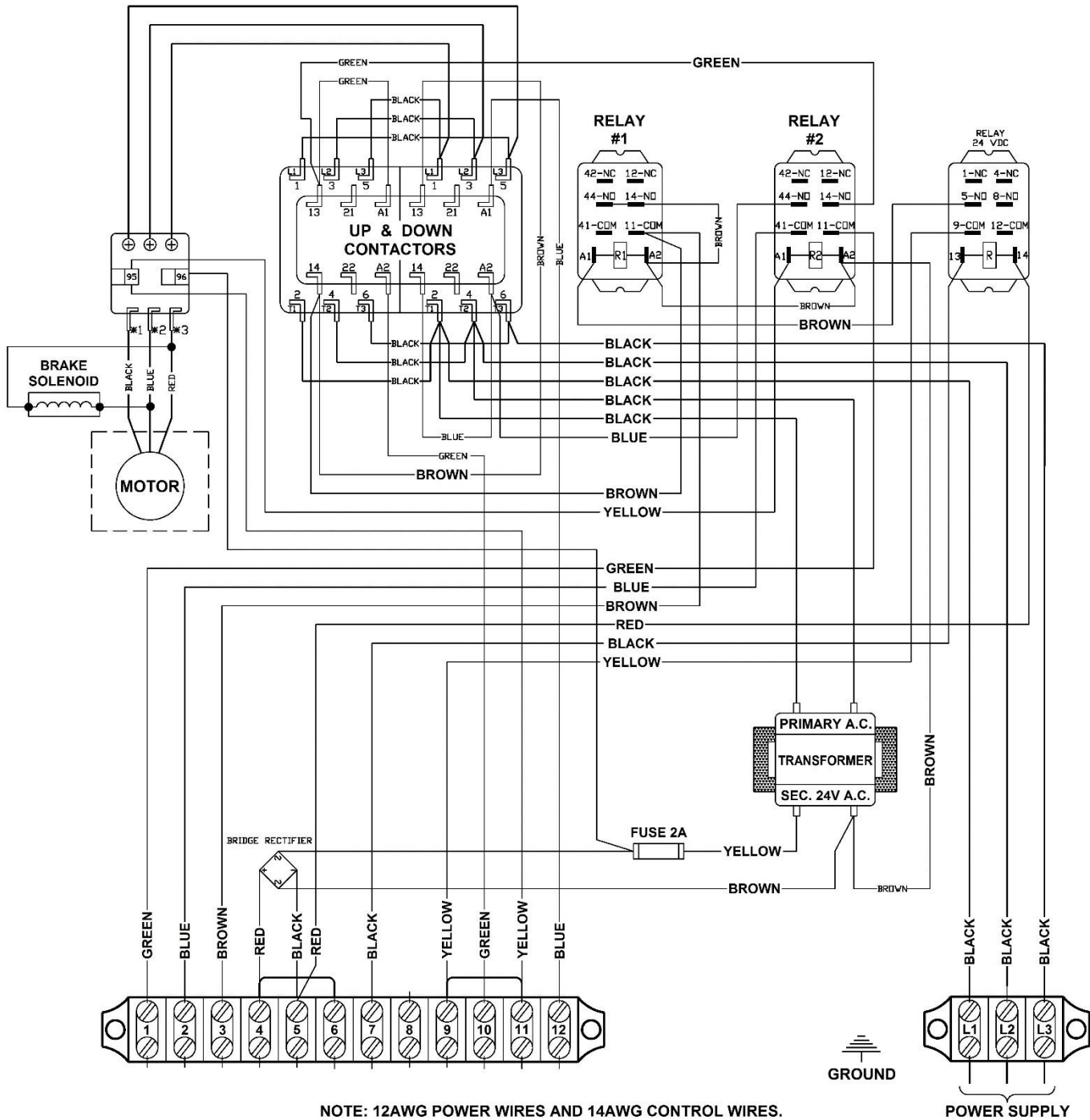

Troubleshooting

Dynamic Brake Wiring Diagram

Single Phase

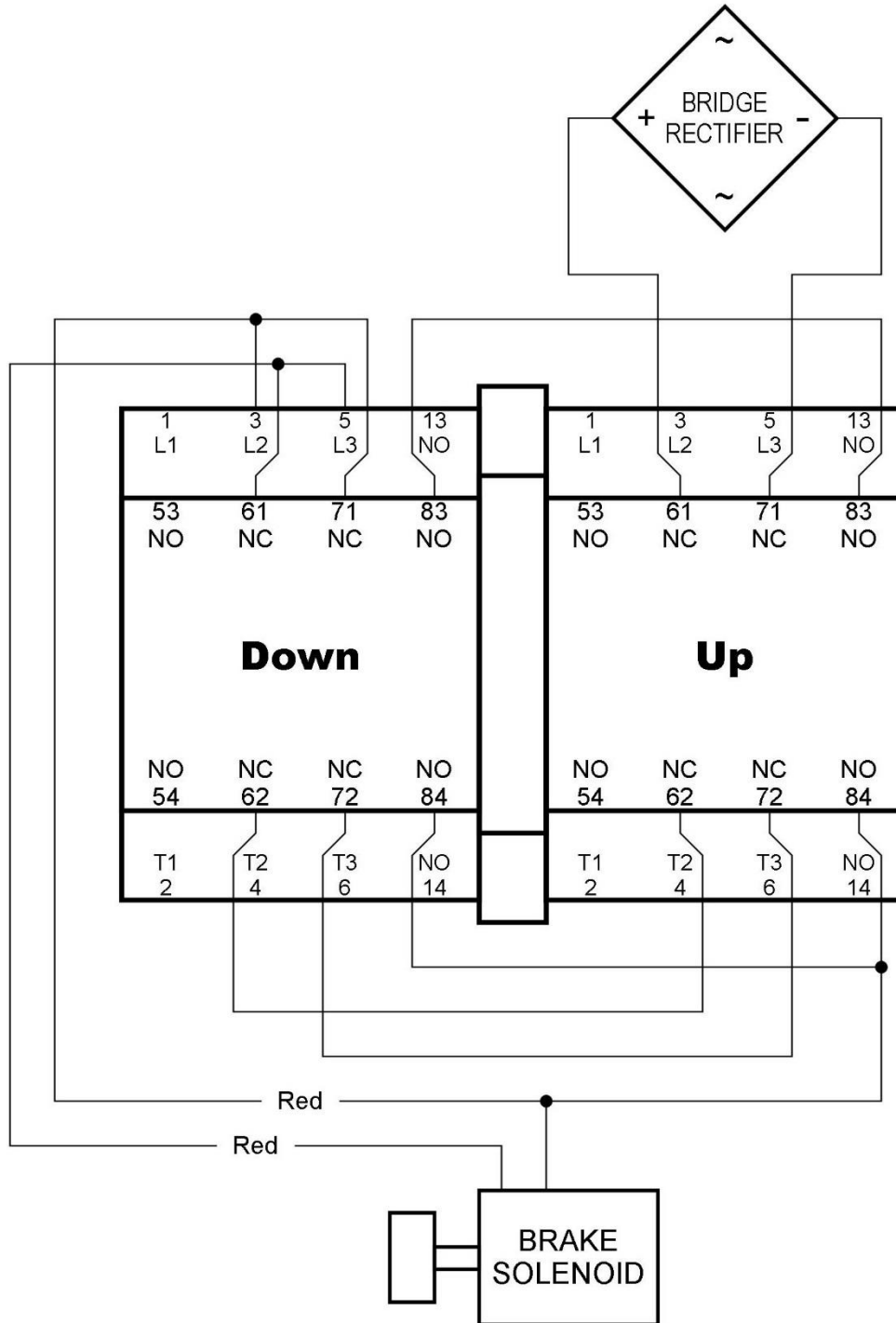

Troubleshooting

Dynamic Brake Wiring Diagram

Three Phase

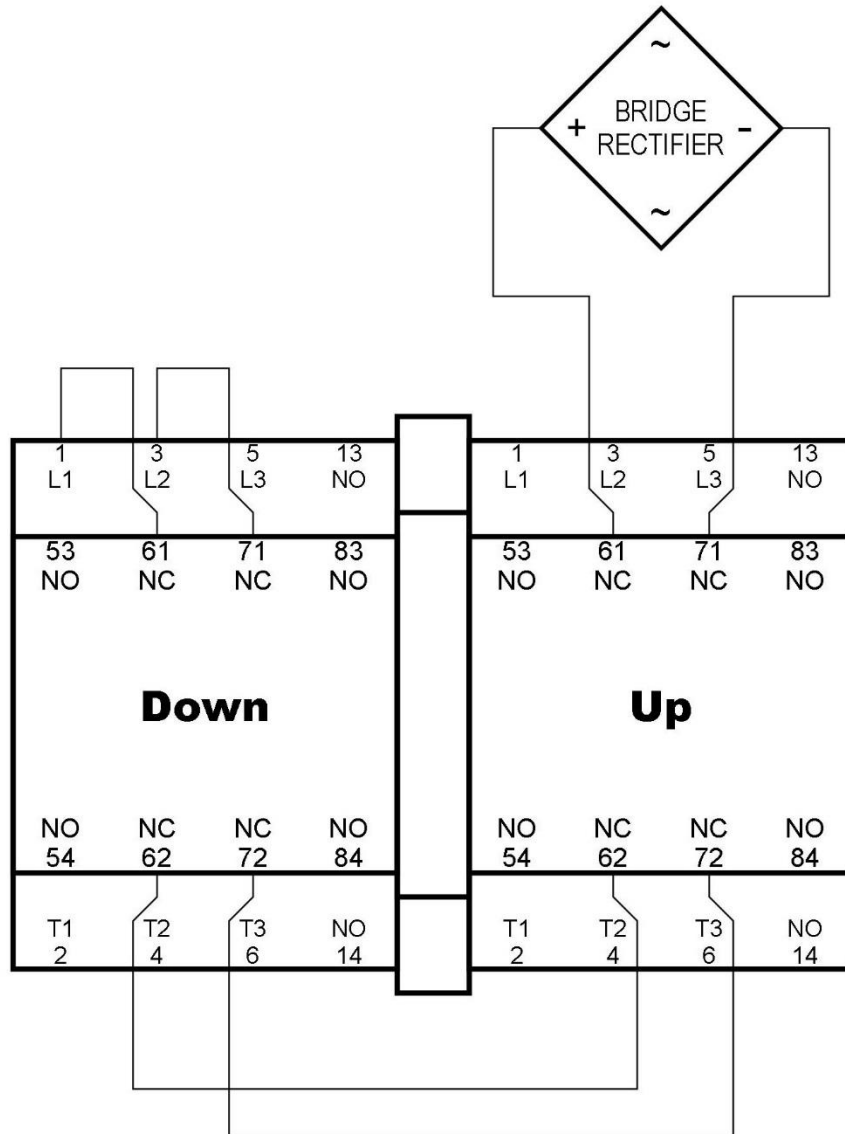

Troubleshooting Controller Wiring Diagram 3-Stop / Single Phase

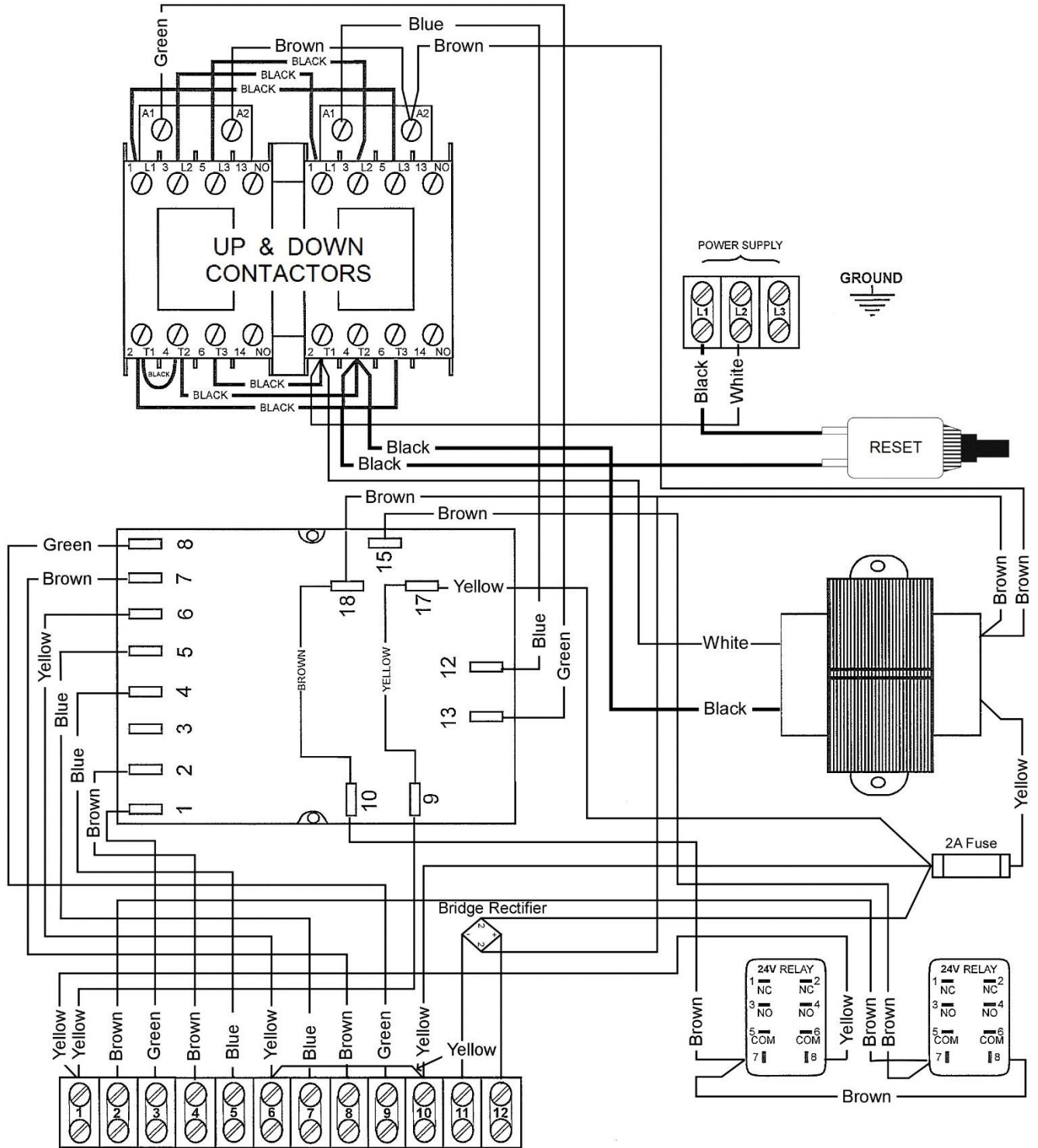

Troubleshooting Controller Wiring Diagram **3-Stop / Three Phase**

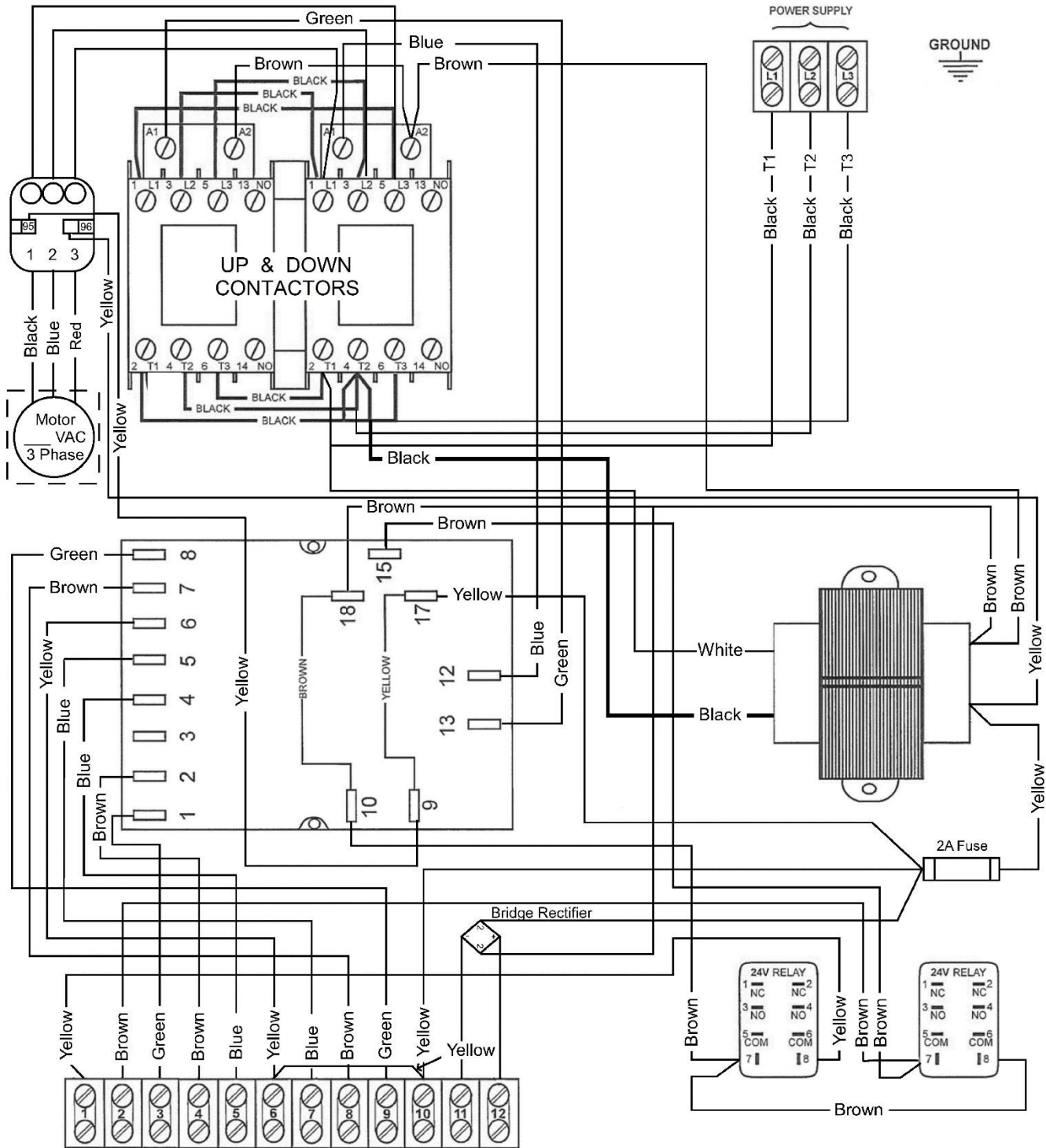

Troubleshooting Controller Wiring Diagram 4-Stop / Single Phase

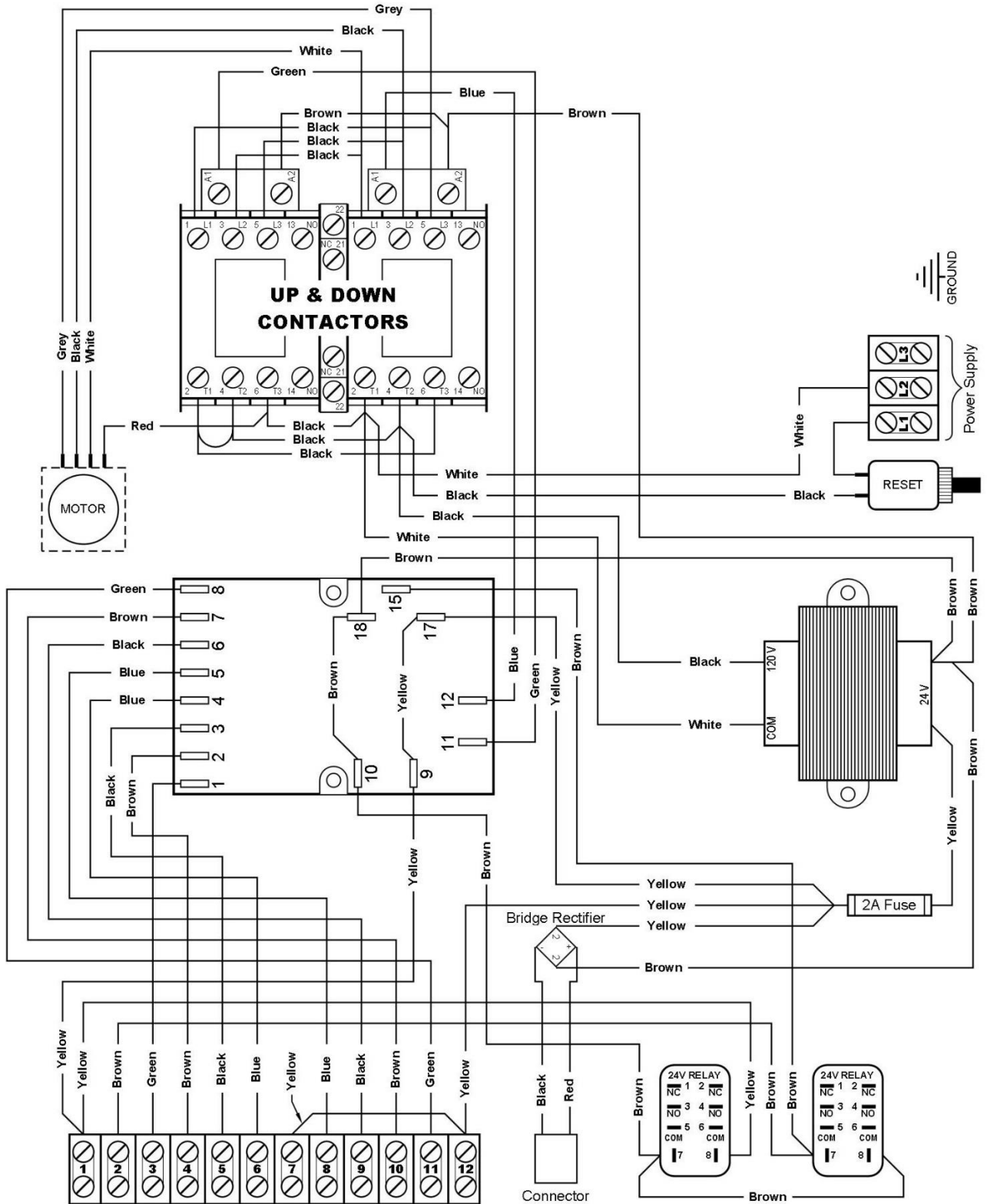

Troubleshooting Controller Wiring Diagram 4-Stop / Three Phase

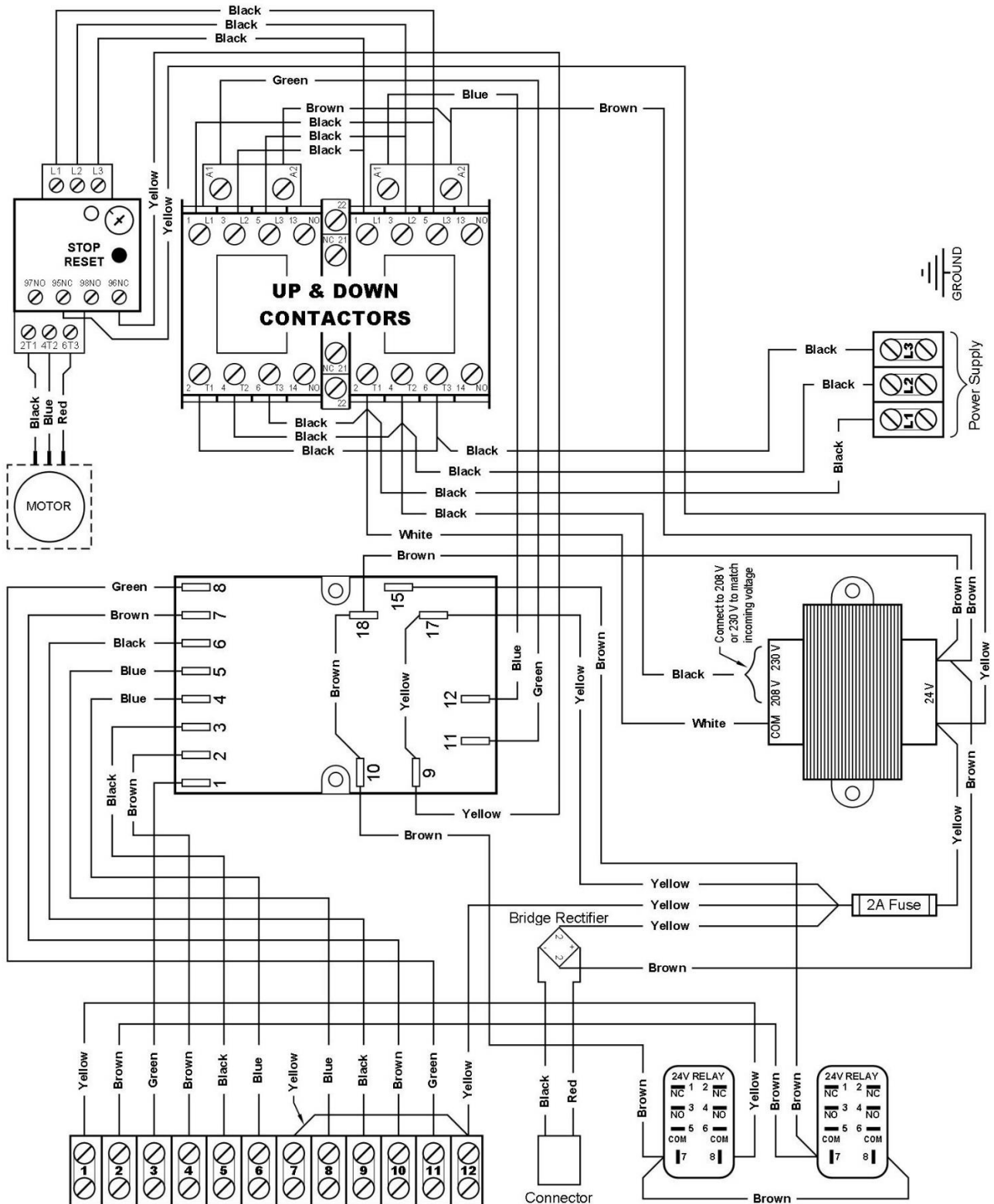

From all of us at
Powerlift Dumbwaiters, Inc.
Thank you for your business.
May God bless you and your family.

www.dumbwaiters.com

1-800-409-5438

HONEYWELL RDI

Mounting Template

For Mounting Interlock on Left
Scale: 1" = 1"

1. Fold template 90° on fold line and place in corner of door and jamb.
2. Center punch holes for temporary mounting of interlock on jamb.
3. Center punch holes for mounting catch on door.
4. Center punch hole for emergency override switch access on door.
5. Predrill temporary mounting holes and catch mounting holes with appropriately sized bit.
6. Drill 5/8" hole for emergency override switch access.
7. Mount interlock to jamb using temporary mounting holes. Mount catch to door.
8. Adjust interlock to receive door catch properly then add 4 corner screws to hold interlock to jamb.

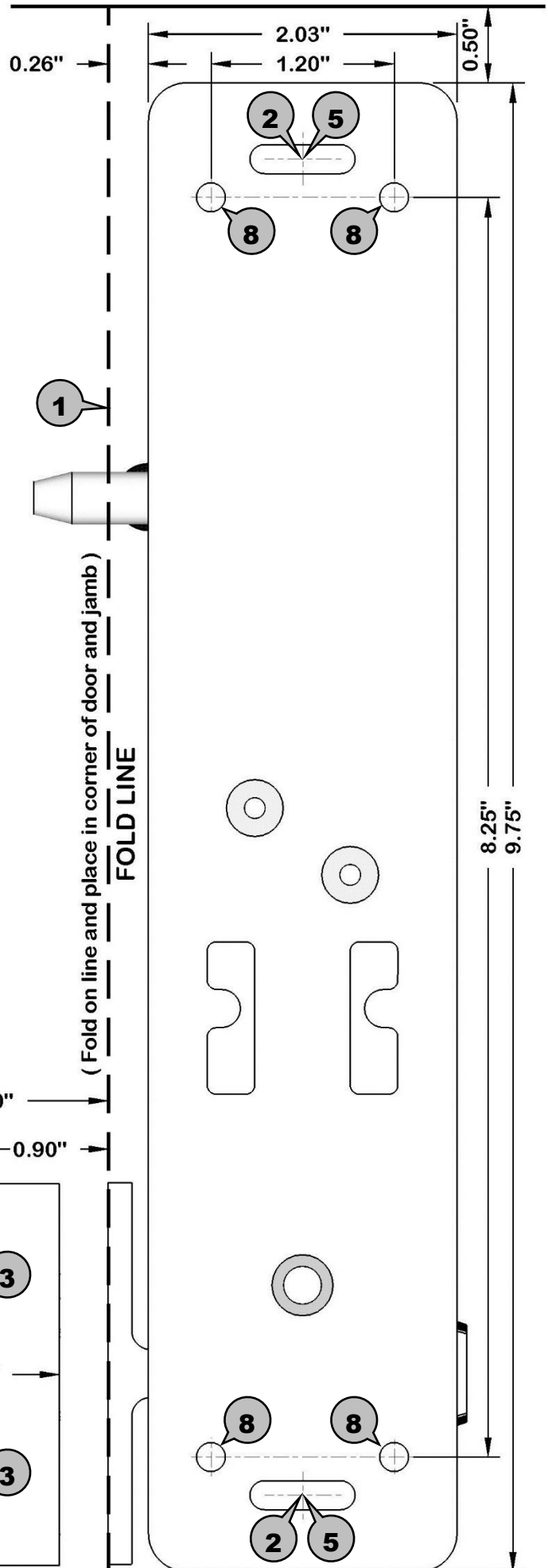
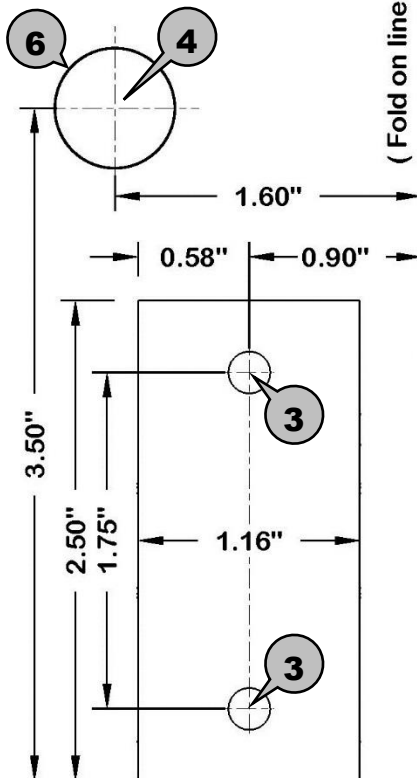

HONEYWELL RDI

Mounting Template

For Mounting Interlock on Right
Scale: 1" = 1"

1. Fold template 90° on fold line and place in corner of door and jamb.
2. Center punch holes for temporary mounting of interlock on jamb.
3. Center punch holes for mounting catch on door.
4. Center punch hole for emergency override switch access on door.
5. Predrill temporary mounting holes and catch mounting holes with appropriately sized bit.
6. Drill 5/8" hole for emergency override switch access.
7. Mount interlock to jamb using temporary mounting holes. Mount catch to door.
8. Adjust interlock to receive door catch properly then add 4 corner screws to hold interlock to jamb.

