

Installation Manual

P-100

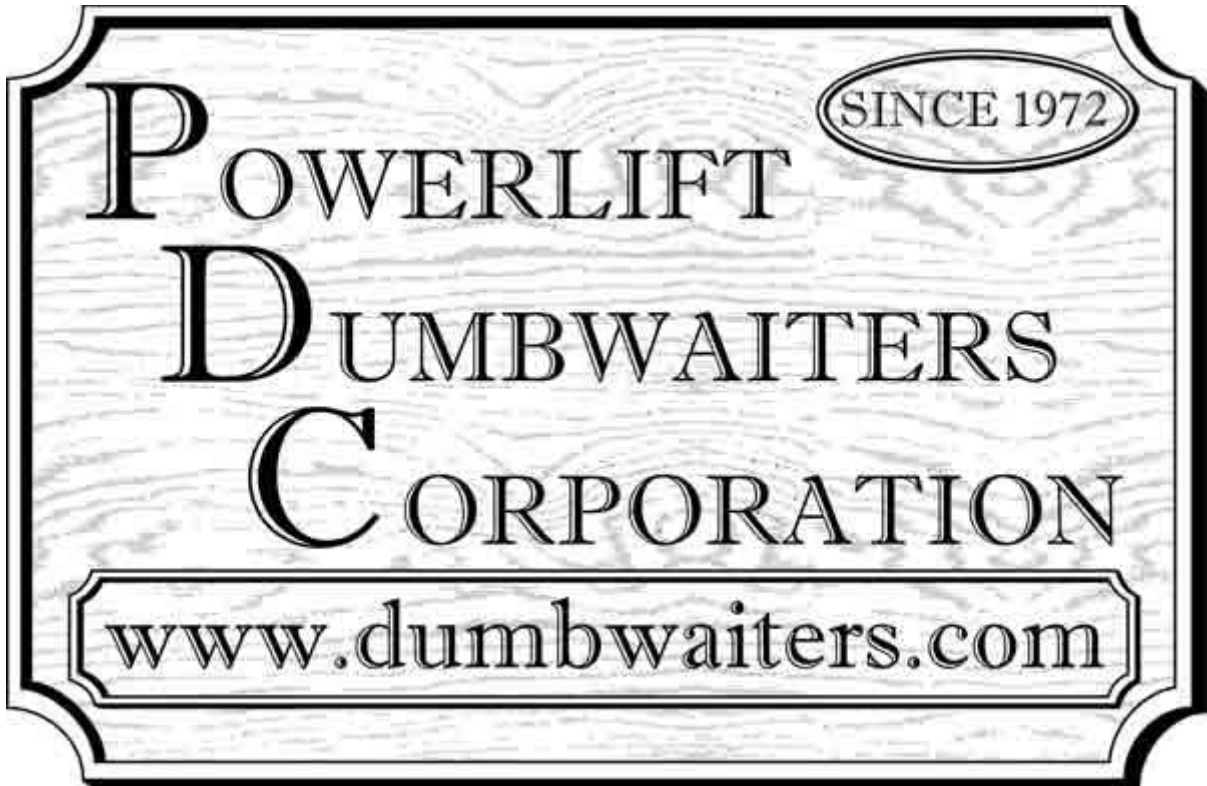

2444 Georgia Slide Road, Georgetown, CA 95634
800-409-5438 • 530-333-1953
Fax: 530-333-1055





Congratulations and thank you for purchasing a Powerlift Dumbwaiter! We are a family owned company, in business for over 40 years, with a commitment to excellence and our customers. Should you have questions or concerns, please do not hesitate to contact us on our toll-free number. We offer free technical support through all phases of your dumbwaiter installation and our staff will be happy to help you.

This installation manual includes information for installing most configurations of the **P-100** and therefore not all information included will apply to your installation. If you are uncertain which configuration you are installing or have any questions, please call us.

Serial # _____

Table of Contents

Important Information _____	5
Dumbwaiter Packaging Contents _____	6
Recommended Wall Backing _____	7
Part 1a Motor Installation _____	8
Part 1b Connecting Wires to T-bar in Controller _____	9
Part 2a Track & Rail Installation (motor on the bottom) _____	10
Part 2b Track & Rail Installation (motor on the top) _____	11
Part 3a Chain Installation (motor on the bottom) _____	12
Part 3b Chain Installation (motor on the top) _____	13
Part 4 Wiring Track & Rail Assembly _____	14
Part 5 Rough Framing & Call/Send Wiring Rough in _____	15
Part 6a Finish Wiring (call/send push buttons & options) _____	16
Part 6b Finish Wiring (door safety switches) _____	17
Part 6c Finish Wiring (power to motor) _____	18
Part 6d Finish Wiring (door lock installation) _____	19
Blank Page for Your Notes _____	20
Part 7 Installing Dumbwaiter Car _____	21
Troubleshooting _____	22
Troubleshooting (2-stop wiring diagram) _____	23
Troubleshooting (3-stop wiring diagram) _____	24
Troubleshooting (4-stop wiring diagram) _____	25

Important Information You Should Know

Please Read

1. Anyone planning to use this dumbwaiter should read the Owner's Manual prior to operating. If you do not have an Owner's Manual, please visit our website to download a copy or call us to have one sent to you.
2. **DO NOT allow children to use the dumbwaiter without adult supervision!**
3. **NEVER OPERATE DUMBWAITER if door safety switches are not working properly.** Every dumbwaiter includes door safety switches, which prevent the dumbwaiter from operating if any door is not properly closed. The switches will also stop the dumbwaiter if any door is opened while the dumbwaiter is in operation. If your door safety switches are not working properly, immediately unplug the dumbwaiter and call Powerlift Dumbwaiters, Inc. to request replacement door safety switches, free of charge for the life of the dumbwaiter. Ensure that the switches are replaced by a qualified technician.
4. **NEVER OPERATE DUMBWAITER if door locks are not working properly.** Every dumbwaiter includes door locks, which prevent the doors from being opened while the dumbwaiter is in operation. If your door locks are not working properly, immediately unplug the dumbwaiter and call Powerlift Dumbwaiters, Inc. to request replacement door locks. Ensure that the door locks are replaced by a qualified technician.
5. **NEVER USE THE DUMBWAITER if it is not operating properly.** Call your service technician, installation contractor, or Powerlift Dumbwaiters, Inc.
6. **NEVER USE THE DUMBWAITER when smoke and/or fire is present.**
7. **DO NOT REMOVE, BYPASS, OR ALTER any switches, controls, and/or restraining devices.** These are mandated by national and local codes and safety regulations. Any tampering will void your warranty and could result in serious injury and/or death.
8. **NEVER EXTEND YOUR HANDS, ARMS, LEGS, FEET, HEAD, OR BODY INTO OPEN HOISTWAY!** Doing so could cause serious injury and/or death! Never extend foreign objects of any kind into open hoistway. Doing so can cause damage to your dumbwaiter and/or serious injury to you!
9. **NO RIDING IN DUMBWAITER CAR!** Your dumbwaiter car is not intended to transport people and/or animals. Doing so could cause serious injury and/or death!
10. **NEVER OVERLOAD YOUR DUMBWAITER CAR!** Your dumbwaiter is rated for a certain capacity. Please see data plate in car.
11. Your dumbwaiter is not designed for continuous operation. Too many "starts" and "stops" could overheat the motor and trip the breaker.
12. The dumbwaiter is designed to operate properly with 20 amps. Use 12 Ga wire for distances up to 25 feet and 10 Ga wire for distances up to 50 feet. In general distances in excess of 50 feet or too many appliances operating from the same power source reduces the available amperage and may cause the lift to malfunction unless a larger gauge wire is used. If your dumbwaiter does not seem to be operating at its optimum, stop using it until it can be inspected by a qualified technician.
13. To prevent unauthorized use, a keyed on/off switch can be obtained from Powerlift Dumbwaiters, Inc.
14. Observe, read, and obey the warning labels, tags, and symbols, as they are provided by the manufacturer for your safety and protection.
15. **DO NOT ATTEMPT TO REPAIR the dumbwaiter yourself.** Immediately stop use, disconnect power supply and call Powerlift Dumbwaiters, Inc. to determine whether you need to contact your service technician or installation contractor.
16. **Check your local fire code.** Swing Hoistway doors may be required to be fire rated and have self closing hinges.

Before You Begin Installation

Proper installation is the responsibility of the installer. A qualified technician should install this dumbwaiter. Make sure you have everything necessary for correct installation. It is the installer's responsibility to ensure the installation complies with the local codes and safety regulations.

Wall construction should be a minimum of 2" x 4" wood studs. Please see the recommended wall backing, on **Page 7**, for our recommended wall framing.

Check the dumbwaiter for damage. Remove all packaging materials and verify that everything is included using the following checklist.

I. In Motor Box:

- Motor
- Parts Box

II. In Parts Box

- Installation Manual
- Owner's Manual
- RCI Door Locks – (1 lock per stop)
 - Four (4) #6-3/4" flat head screws – (4 screws per lock)
 - Two (2) M4 x 0.7 x 30mm hex head cap screws – (2 screws per lock)
 - Two (2) M4 x 0.7 x 50mm hex head cap screws – (2 screws per lock)
 - Two (2) M4 lock washers – (2 lock washers per lock)
 - Two (2) M4 x 0.7 cap nuts – (2 screws per lock)
- Parts Bags

III. In Parts Bags

- Frame Clips – (1 frame clip per track section)
- 2" Coarse Screws for Frame Clips – (1 screw per frame clip)
- Stacking Pins – (2 stacking pins per track section, less top section)
- 3" Lag Screws – (quantity varies)
- 1/4" x 2 1/4" Bolts & Flange Nuts – (quantity varies)
- Faceplate w/Push Buttons & 2 Faceplate Screws – (1 per stop)
- Wire Nuts – (quantity varies)
- Door Safety Switch & 2 Screws – (1 for motor access panel & 1 per stop)
- Two (2) 1/4"-20 x 1 3/4" Bolts & Washers for Mounting Car

Recommended Wall Backing

Vertical Backing for 16" wide Rails

Locate and mark centerline on the mounting wall. Measure and mark 6½" on both sides of centerline. These two marks, 13" apart, represent the centerline of your vertical backing. Install 2x6's centered on each mark with the 6" side facing into the shaft and running vertically up the entire shaft.

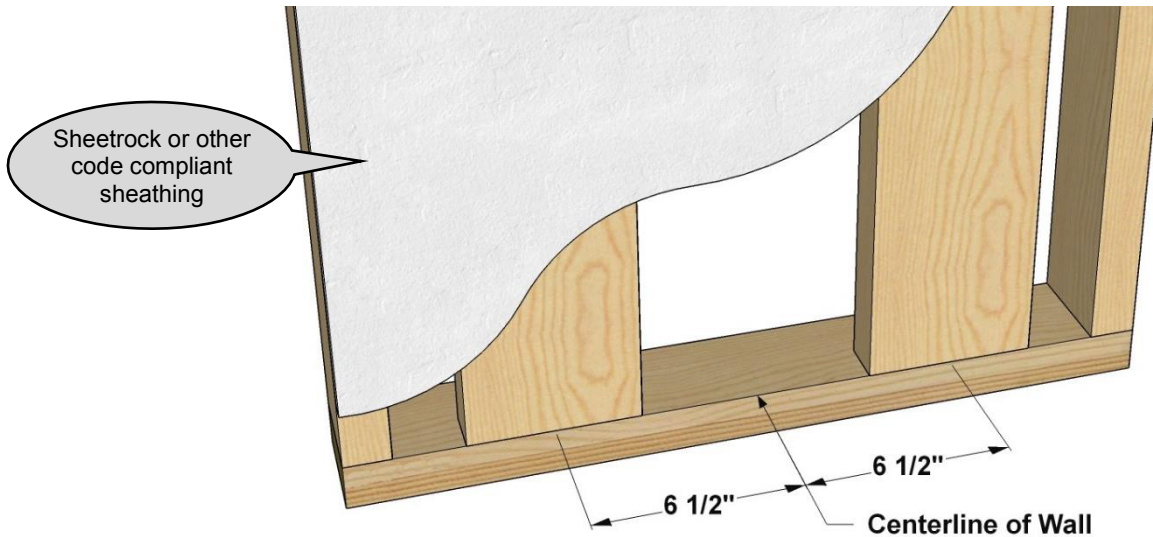

Vertical Backing for 20" wide Rails

Locate and mark centerline on the mounting wall. Measure and mark 8½" on both sides of centerline. These two marks, 17" apart, represent the centerline of your vertical backing. Install 2x6's centered on each mark with the 6" side facing into the shaft and running vertically up the entire shaft.

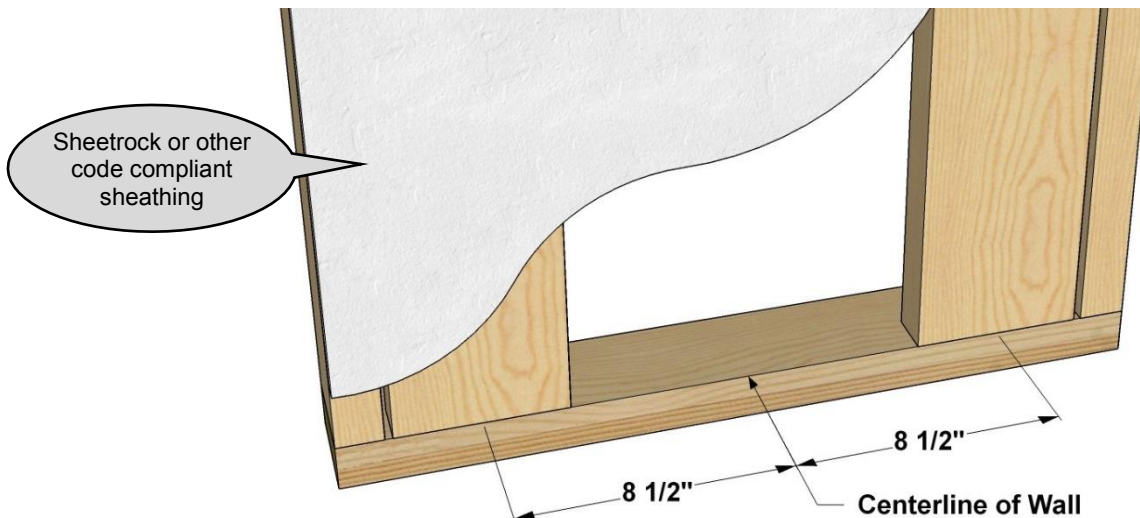

PART 1a

Motor Installation

- 1 Place motor section of track horizontally on a flat surface.
- 2 Remove motor from box and place it on track & rail section from Step 1. (see Figure 1)
- 3 Use four (4) provided bolts, washers, and nyloc nuts to securely fasten motor to track & rail section. (see Figure 1)
- 4 Use factory installed wires from junction box, on the rail next to the motor, to wire in the motor controller. (see Figure 1)

Note: Use the wiring diagram on **Page 9** to properly connect the wires to the T-bar.

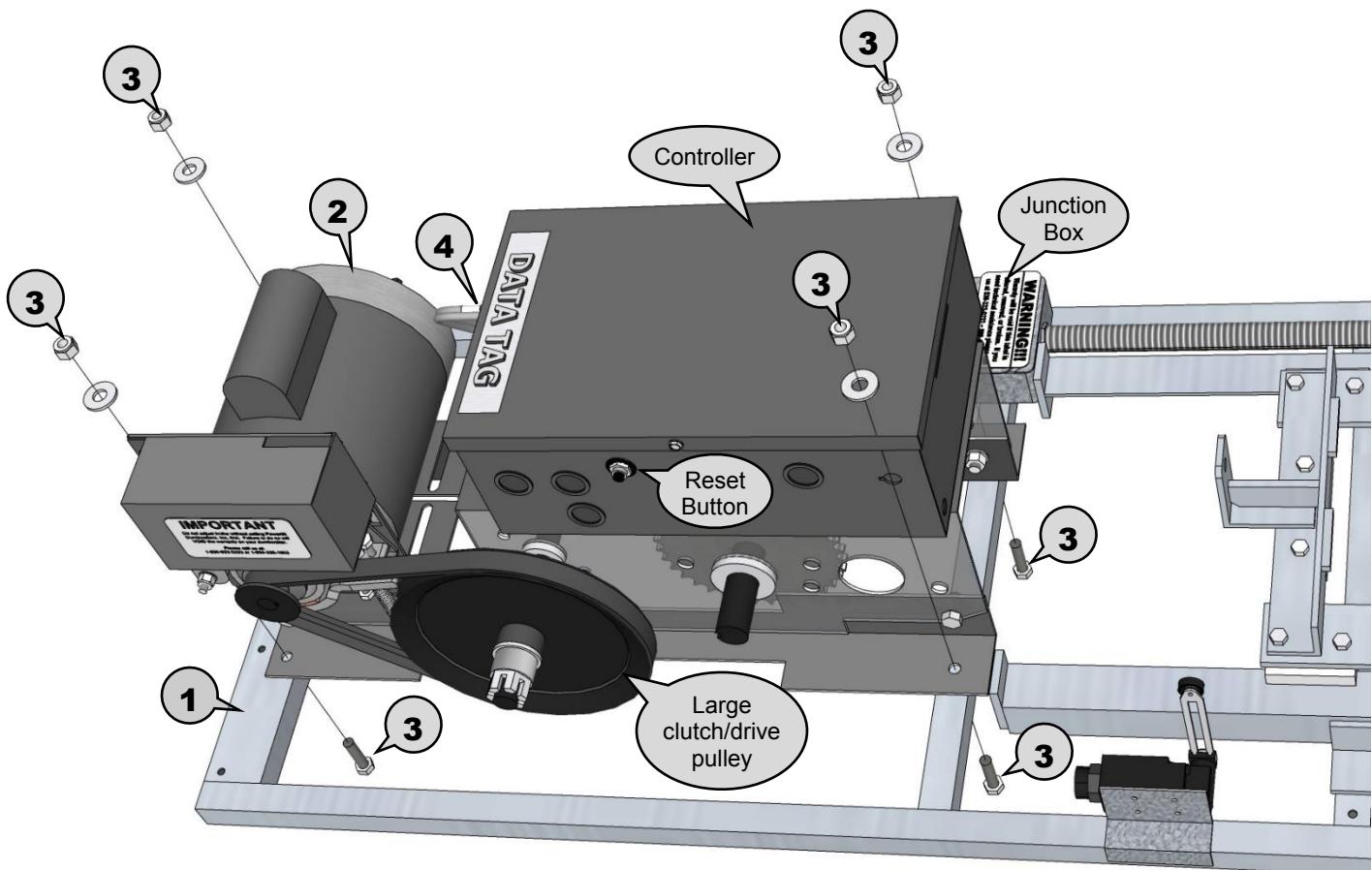
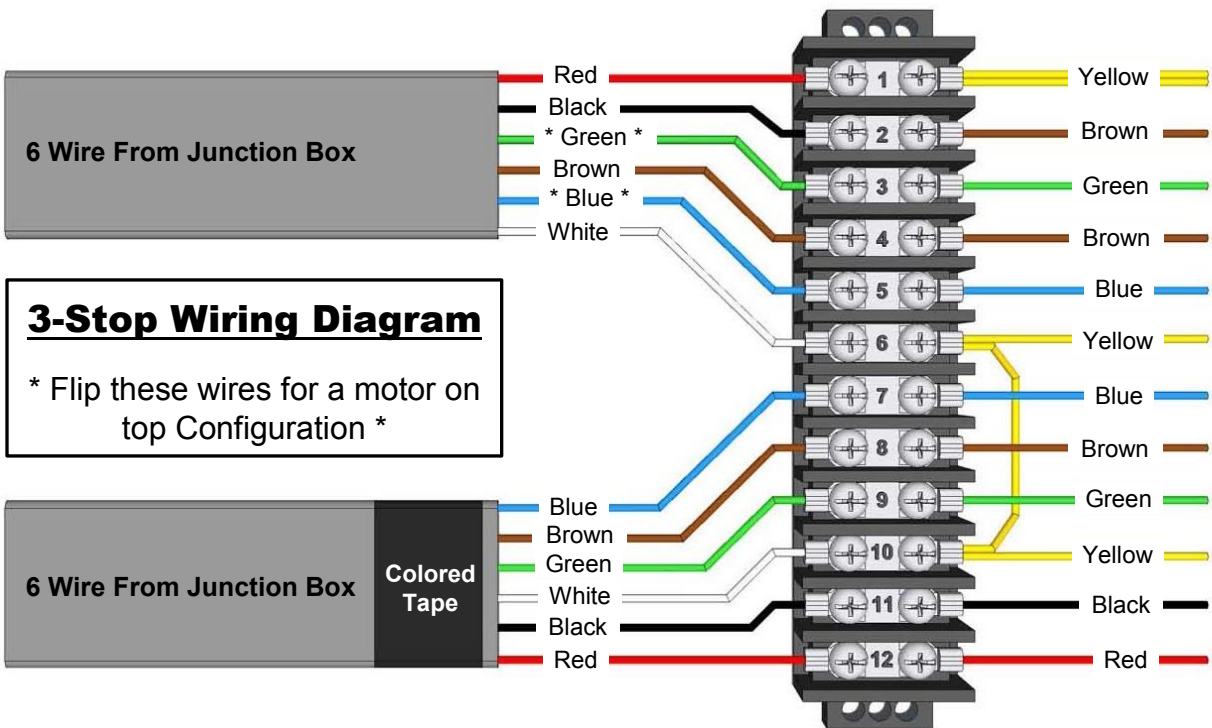
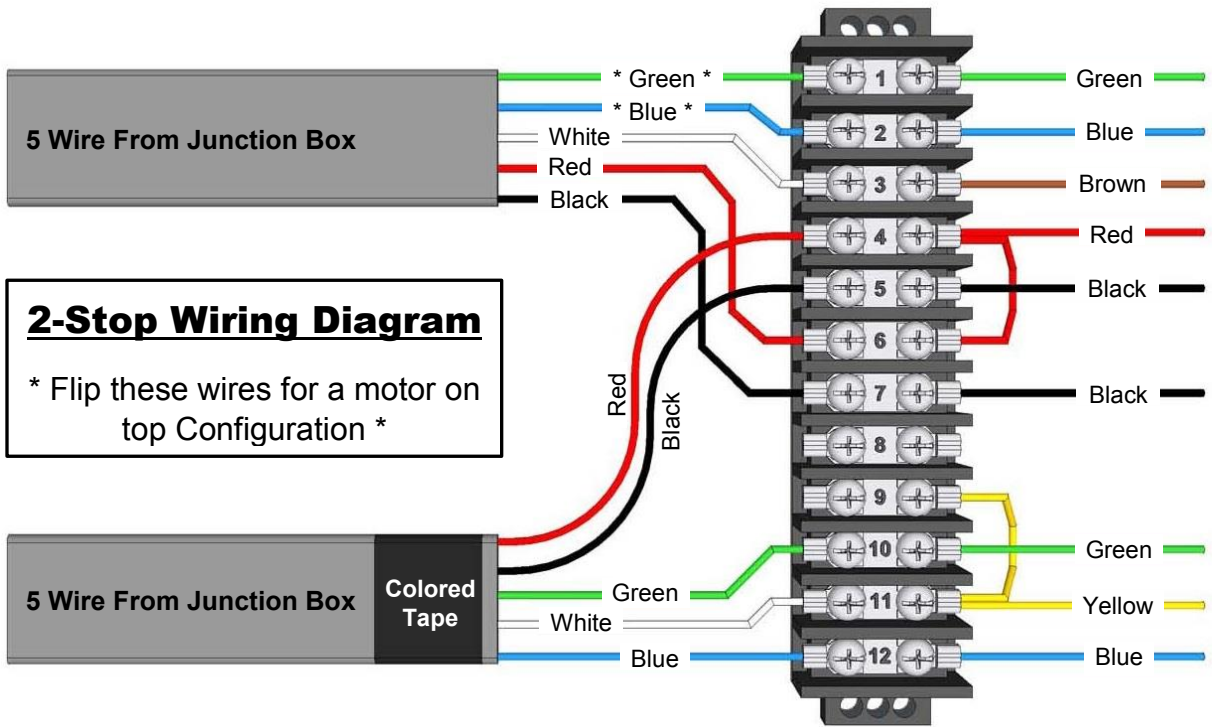

Figure 1

NOTE: For motor on top configuration, make sure the chain bundle is positioned down the track & rail in between track and not behind rail. (see Page 11, Figures 4 & 5, 9)

PART 1b

Connecting Wires to T-bar in Controller



PART 2a

Track & Rail Installation

Motor on Bottom Configuration

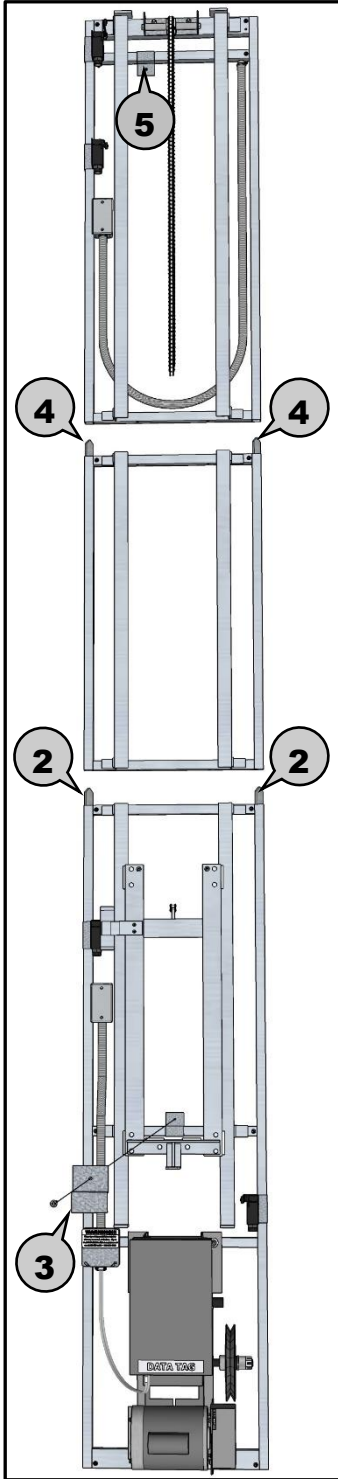

Figure 2

- 1** Before stacking the dumbwaiter into place, be sure that you have backing in or on the wall, as recommended (**see Page 7**), to which the track & rail assembly will be mounted.
- 2** Drop two (2) stacking pins into the top of the two outer vertical tubes of the bottom section, and position section centered against the mounting wall. (**see Figure 2**)
- 3** Use provided frame clip and 2" screw to temporarily hold section in place against the wall. Make sure screws go into solid wood. (**see Figure 2**)
- 4** Drop two (2) stacking pins into the top of the two outer vertical tubes of the next section, and position section on top of previous section using the stacking pins to guide it into place centered against the mounting wall. (**see Figure 2**)
- 5** Use provided frame clip and 2" screw to temporarily hold section in place against the wall. Make sure screws go into solid wood. (**see Figure 2**)
- 6** Use two (2) ¼" x 2 ¼" bolts & nuts to fasten sections together. (**see Figure 3**)

NOTE: Before tightening the bolts, be sure the tracks are in line and there is a smooth transition between the two sections.

- 7** Repeat steps 4 thru 6 for each additional section. **NOTE:** After stacking the top section, make sure that it is centered on the mounting wall.
- 8** Use provided 3" lag screws to fasten track & rail assembly to wall. (**see Figure 3**)

NOTE: When fastening track & rail assembly to the wall, verify the track is centered on the mounting wall through the entire shaft and that there is a smooth transition between track sections. Overtightening the lag bolts can pull the track out of alignment. If necessary use shims between wall and frames to align tracks. For very small adjustments a crescent wrench can be used to bend track until aligned.

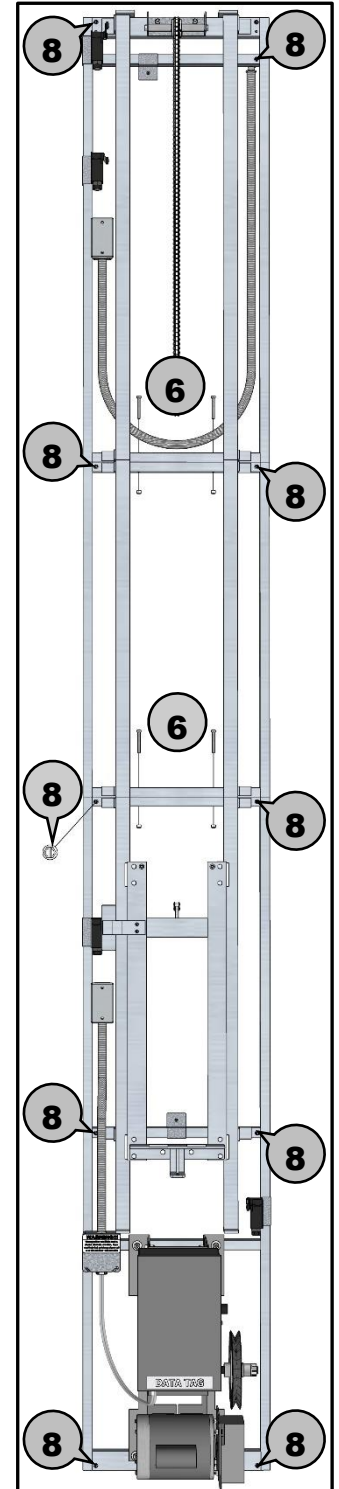

Figure 3

PART 2b

Track & Rail Installation

Motor on Top Configuration

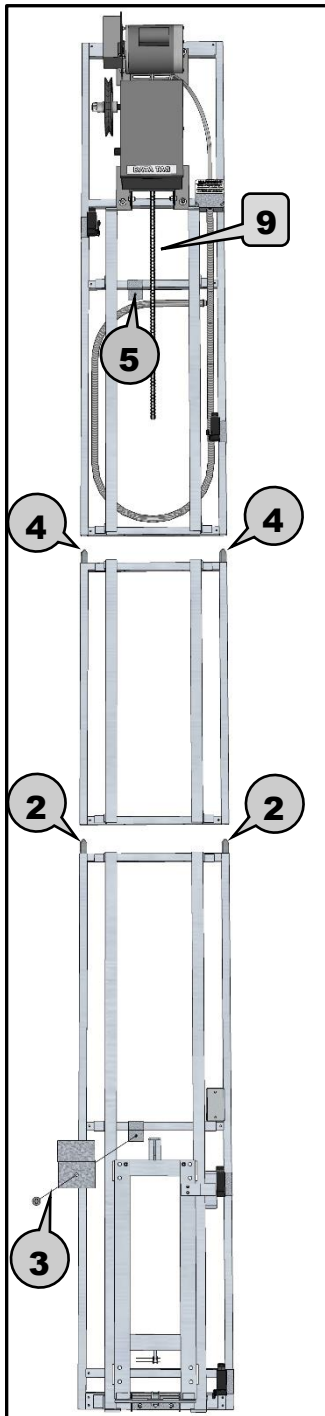

Figure 4

- 1** Before stacking the dumbwaiter into place, be sure that you have backing in or on the wall, as recommended (see Page 7), to which the track & rail assembly will be mounted.
 - 2** Drop two (2) stacking pins into the top of the two outer vertical tubes of the bottom section, and position section centered against the mounting wall. (see Figure 4)
 - 3** Use provided frame clip and 2" screw to temporarily hold section in place against the wall. Make sure screws go into solid wood. (see Figure 4)
 - 4** Drop two (2) stacking pins into the top of the two outer vertical tubes of the next section, and position section on top of previous section using the stacking pins to guide it into place centered against the mounting wall. (see Figure 4)
 - 5** Use provided frame clip and 2" screw to temporarily hold section in place against the wall. Make sure screws go into solid wood. (see Figure 4)
 - 6** Use two (2) 1/4" x 2 1/4" bolts & nuts to fasten sections together. (see Figure 5)
- NOTE:** Before tightening the bolts, be sure the tracks are in line and there is a smooth transition between the two sections.
- 7** Repeat steps 4 thru 6 for each additional section.
- NOTE:** After stacking the top section, make sure that it is centered on the mounting wall.
- 8** Use provided 3" lag screws to fasten track & rail assembly to wall. (see Figure 5)

NOTE: When fastening track & rail assembly to the wall, verify the track is centered on the mounting wall through the entire shaft and that there is a smooth transition between track sections. Overtightening the lag bolts can pull the track out of alignment. If necessary use shims between wall and frames to align tracks. For very small adjustments a crescent wrench can be used to bend track until aligned.

- 9** See Note at bottom of Page 8.

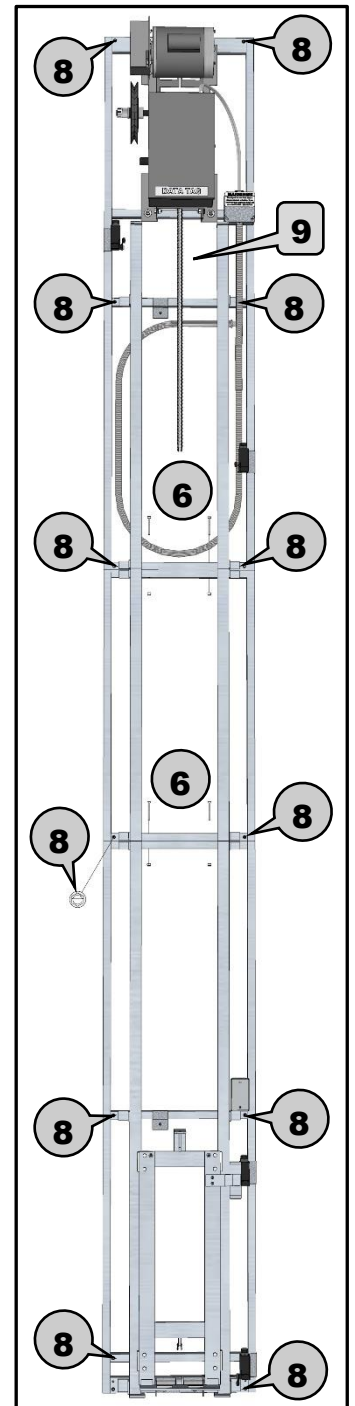

Figure 5

PART 3a

Chain Installation

Motor on Bottom Configuration

⚠ WARNING ⚠

NEVER INSTALL CHAIN UNLESS A.C. POWER IS DISCONNECTED FROM DUMBWAITER! FAILURE TO DO SO COULD DAMAGE THE DUMBWAITER AND/OR CAUSE SERIOUS BODILY INJURY, LOSS OF LIMB, OR DEATH!

- 1** The chain is bundled and tied to the top track & rail section. Only cut the **white** plastic ties holding the chain to the track.
- 2** Cut the **white** plastic ties holding the chain to the idler shaft, one at a time, in the order they are labeled and carefully lower the chain to prevent tangling.

NOTE: Do not cut the black plastic tie! (see Figure 6)

- 3** Cut any remaining **white** plastic ties.
- 4** Use provided master link, attached near the top of the trolley with a plastic tie, to connect chain to top end of trolley. (see Figure 7)

⚠ WARNING ⚠

MAKE SURE THAT THE MASTER LINK IS FASTENED SECURELY! FAILURE TO DO SO COULD DAMAGE THE DUMBWAITER AND/OR CAUSE SERIOUS BODILY INJURY, LOSS OF LIMB, OR DEATH!

- 5** The other end of the chain should hang down behind the trolley and be placed around the drive sprocket of the motor. Then insert the threaded adjusting bolt, on the end of the chain, into the hole on the bottom of the trolley, where the adjusting nut is tied on, and use the adjusting nut to secure the adjusting bolt to the trolley. Use a blade screwdriver or needle nose pliers to hold chain from twisting and tighten adjusting nut until Nyloc nut is tightly seated against trolley. **Do not adjust Nyloc!** (see Figure 8)

NOTE: If the adjusting bolt won't reach, turn large pulley (see Page 8, Figure 1) to take up any slack in the chain.

⚠ WARNING ⚠

MAKE SURE THAT THE CHAIN IS COMPLETELY SEATED ON THE DRIVE SPROCKET! FAILURE TO DO SO COULD DAMAGE THE DUMBWAITER AND/OR CAUSE SERIOUS BODILY INJURY, LOSS OF LIMB, OR DEATH!

- 6** Some machines will have a trolley stop screwed to the track for shipping purposes, and it should be removed at this time. (see Figure 7)
- 7** Cut black plastic tie off. (see Figure 6)

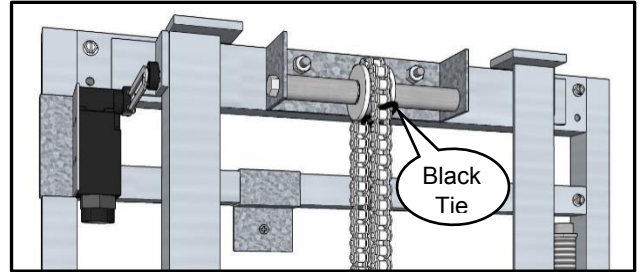

Figure 6

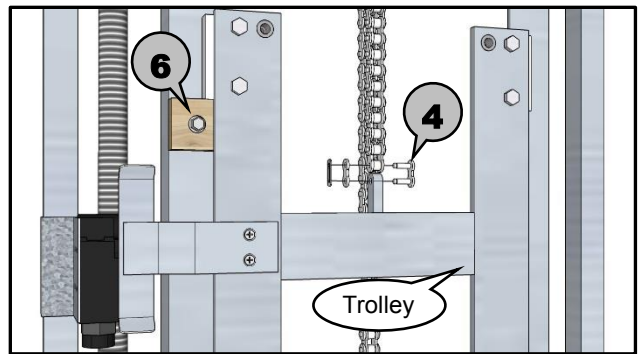

Figure 7

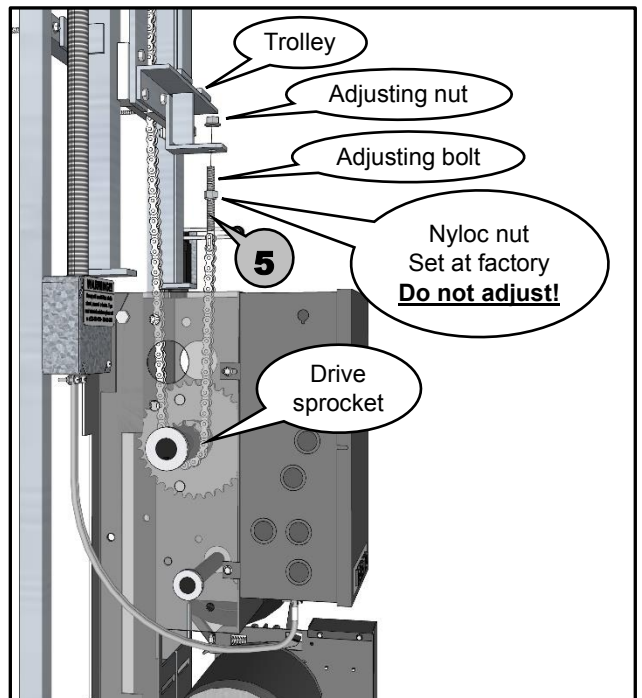

Figure 8

PART 3b

Chain Installation

Motor on Top Configuration

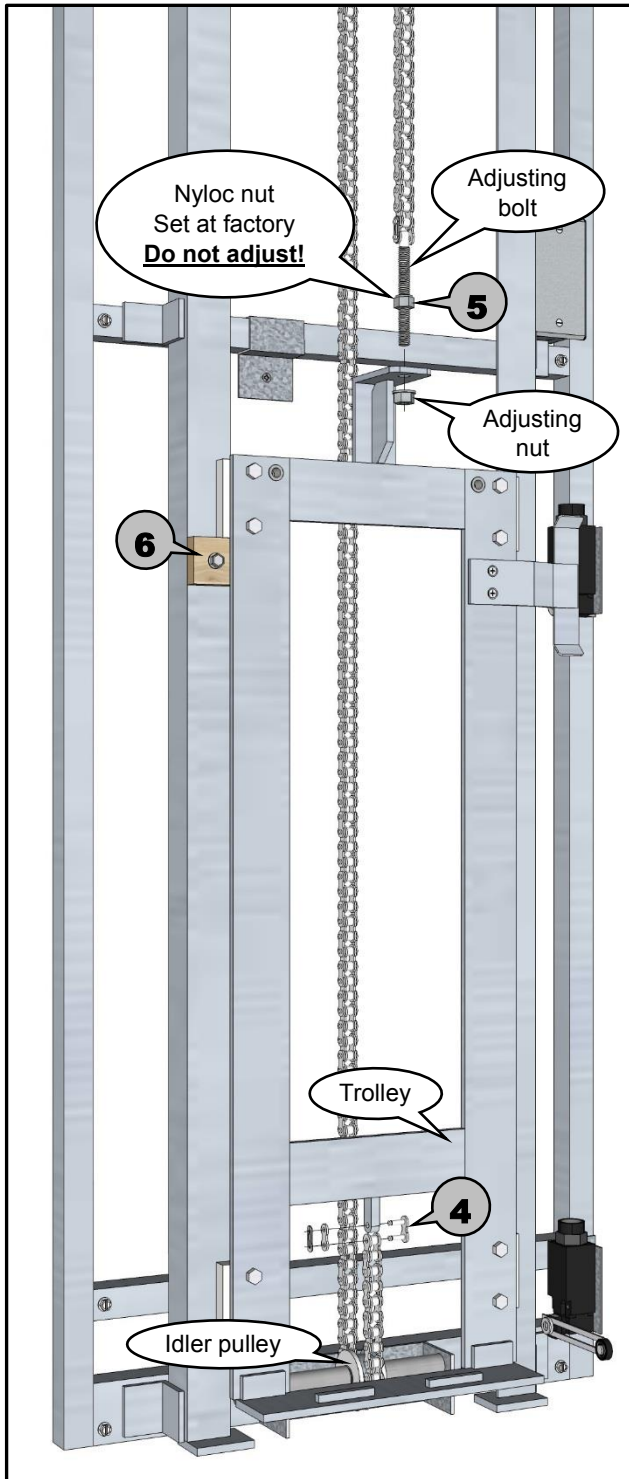

Figure 9

⚠ WARNING ⚠

NEVER INSTALL CHAIN UNLESS A.C. POWER IS DISCONNECTED FROM DUMBWAITER! FAILURE TO DO SO COULD DAMAGE THE DUMBWAITER AND/OR CAUSE SERIOUS BODILY INJURY, LOSS OF LIMB, OR DEATH!

- 1 The chain is bundled and tied to the motor. Only cut the **white** plastic ties holding the chain bundle to the motor.
- 2 Cut the **white** plastic ties holding the chain to the motor shaft, one at a time, in the order they are labeled and carefully lower the chain to prevent tangling.

NOTE: Do not cut the black plastic tie!

- 3 Cut any remaining **white** plastic ties.
- 4 One end of the chain should hang down behind the trolley and be placed around the idler pulley. Then use provided master link, attached near the bottom of the trolley with a plastic tie, to connect chain to bottom end of trolley. (see Figure 9)

⚠ WARNING ⚠

MAKE SURE THAT THE MASTER LINK IS FASTENED SECURELY! FAILURE TO DO SO COULD DAMAGE THE DUMBWAITER AND/OR CAUSE SERIOUS BODILY INJURY, LOSS OF LIMB, OR DEATH!

- 5 The other end of the chain with the adjusting bolt should hang down near the top of the trolley. Insert the threaded adjusting bolt, on the end of the chain, into the hole on the top of the trolley where the adjusting nut is tied on, and use the adjusting nut to secure the adjusting bolt to the trolley. Use a blade screwdriver or needle nose pliers to hold chain from twisting and tighten adjusting nut until Nyloc nut is tightly seated against trolley. **Do not adjust Nyloc!** (see Figure 9)
- 6 Some machines will have a trolley stop screwed to the track for shipping purposes, and it should be removed at this time. (see Figure 9)
- 7 Cut black plastic tie, next to the drive sprocket, off. (see Page 12, Figure 8, for sprocket location)

PART 4

Wiring Track & Rail Assembly

⚠ WARNING ⚠

**MAKE SURE A.C. POWER IS DISCONNECTED FROM DUMBWAITER!!
FAILURE TO DO SO COULD DAMAGE THE DUMBWAITER AND/OR CAUSE
SERIOUS BODILY INJURY, LOSS OF LIMB, OR DEATH!**

- 1 Lower flex conduit from top floor and connect to junction box at bottom floor. (see Figures 10 & 11)

NOTE: Check female connectors for metal shavings and clean them out if necessary.

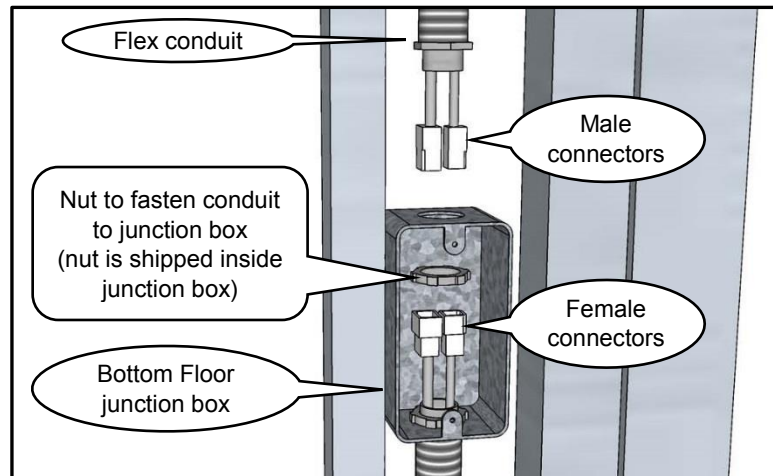

Figure 11

- 2 On 2-stop dumbwaiters, one set of wires has female connectors and the other set has male connectors. Match up each male and female connector and seat them firmly together. (see Figure 12)

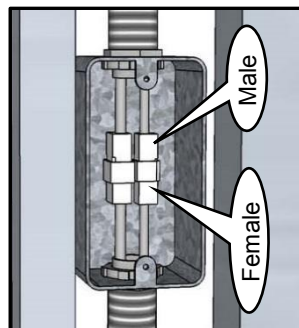

Figure 12

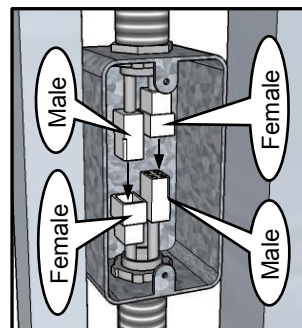

Figure 13

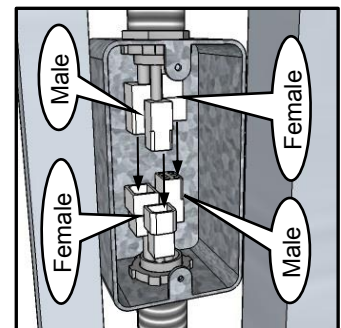

Figure 14

- 3 On 3-stop & 4-stop dumbwaiters, the wires dropping down will have male and female connectors as will the junction box. Make sure the male and female from above plug into the male and female from below. (for 3-stops see Figure 13) (for 4-stops see Figure 14)

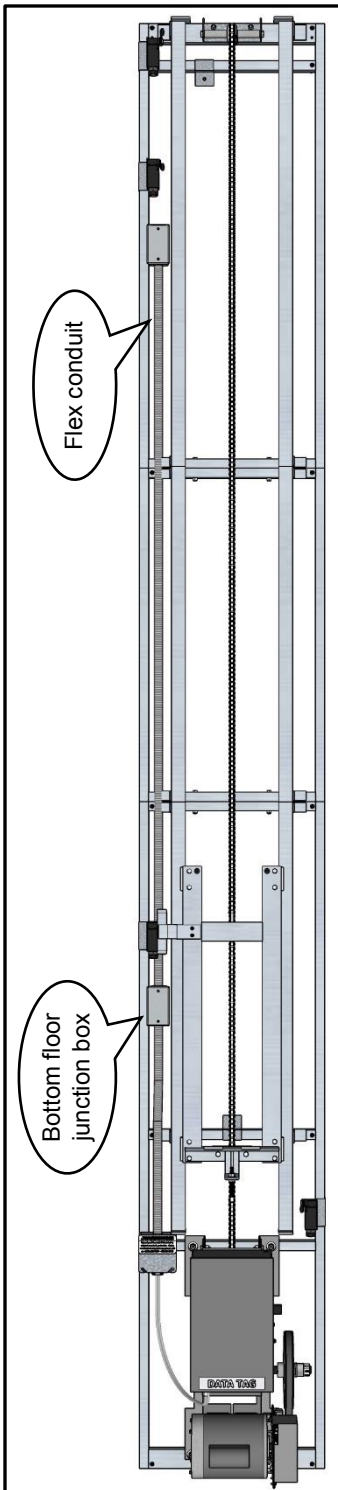

Figure 10

PART 5

Rough Framing & Call/Send Wiring Rough in

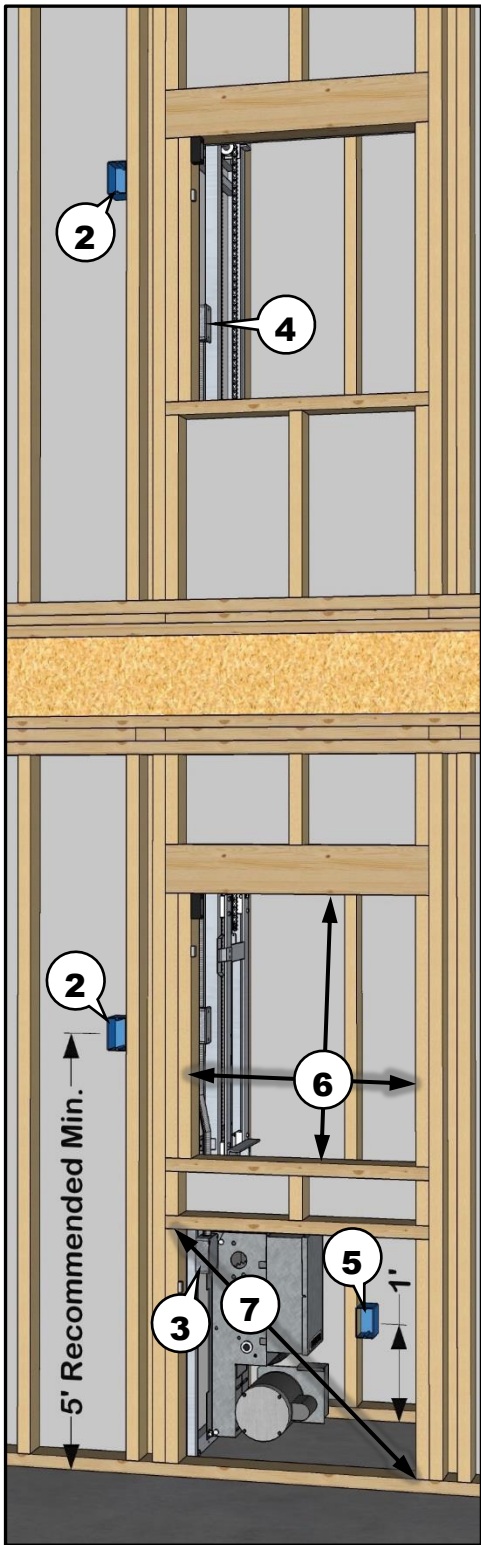

Figure 15

⚠ WARNING ⚠

MAKE SURE A.C. POWER IS DISCONNECTED FROM DUMBWAITER!!
FAILURE TO DO SO COULD DAMAGE THE DUMBWAITER AND/OR CAUSE
SERIOUS BODILY INJURY, LOSS OF LIMB, OR DEATH!

- 1 Use standard framing to construct hoistway (dumbwaiter shaft). (see Page 7 for wall backing)
NOTE: It is the responsibility of the contractor to build the hoistway (dumbwaiter shaft) according to your local codes and regulations.

⚠ WARNING ⚠

INSTALL PUSH BUTTONS OUT OF REACH OF CHILDREN AT A
RECOMMENDED MINIMUM HEIGHT OF 5 FEET (1.5 M), AND IN A LOCATION
TO PREVENT UNINTENTIONAL ACTIVATION. FAILURE TO DO SO COULD
DAMAGE THE DUMBWAITER AND/OR CAUSE SERIOUS BODILY INJURY,
LOSS OF LIMB, OR DEATH!

- 2 Place push button boxes per owner's instruction, making sure there is enough wire to reach the box. (see Figure 15)

- 3 Rough-in wire for push buttons from junction box to bottom floor push button box. (see Figure 15)
- 4 Rough-in wire for push buttons from top floor junction box to top floor push button box. (see Figure 15)
- 5 Install power supply junction box, on a dedicated 20A circuit, 12 inches (0.3 m) above floor on wall adjacent to mounting wall. (see Figure 15)
NOTE: Do not install junction box on wall where track & rail is to be mounted!

- 6 The first floor finished jam should be larger than the dumbwaiter car for installation or removal of car for servicing.

⚠ IMPORTANT ⚠

A CAR 24" w X 24" d X 30" h NEEDS ONE "FINISHED" OPENING TO
MEASURE 25" w X 31" h FOR INSTALLING THE CAR AND FOR REMOVAL
OF THE CAR TO SERVICE THE DUMBWAITER SAFELY.

- 7 Removable access panel or door for servicing motor, brake, clutch, or car adjustment. (see Figure 15)

⚠ IMPORTANT ⚠

CODE REQUIRES ALL DUMBWAITERS TO HAVE A MOTOR ACCESS
PANEL OR A LOCKABLE DOOR TO SERVICE THE DUMBWAITER SAFELY.

PART 6a

Finish Wiring

Call/Send Push Buttons & Options

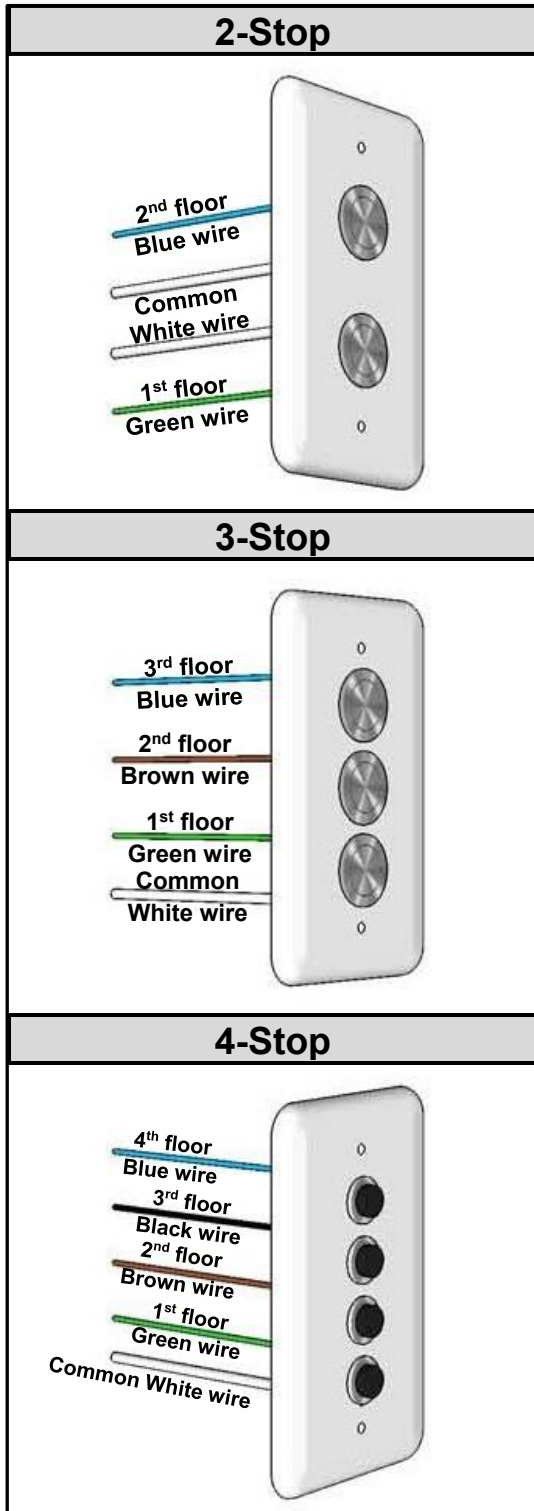

Figure 16

⚠ WARNING ⚠

MAKE SURE A.C. POWER IS DISCONNECTED FROM DUMBWAITER!!
FAILURE TO DO SO COULD DAMAGE THE DUMBWAITER AND/OR
CAUSE SERIOUS BODILY INJURY, LOSS OF LIMB, OR DEATH!

- 1** To wire in push buttons; match same color wires from box in wall and push buttons, together, and twist on provided wire nuts. (i.e., blue to blue, green to green, etc.)
- 2** Secure wire nut connections with electrical tape.
- 3** Use provided screws to screw push button wall plate to box in wall.

Push Button Options

If you ordered the “keyed on/off lock” or the “car here lights”, you will have additional wires to secure as described below.

- The car here lights always have red and black wires.
- The keyed lock or emergency stop button without the car here lights will have a red and black wire.
- The keyed lock or emergency stop button with the car here lights, will have an orange and yellow wire.

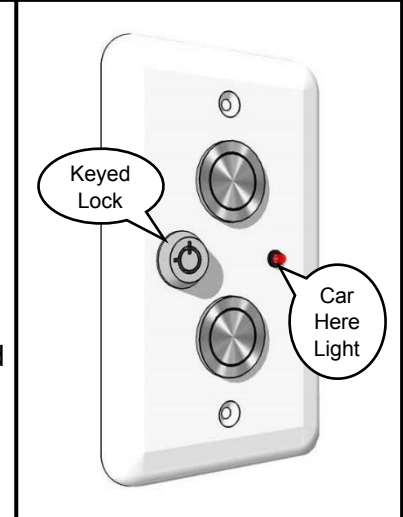

Figure 17

NOTE:
4-stop machines will have a separate 2 conductor wire for two options. The separate conductor is labeled accordingly.

PART 6b

Finish Wiring

Door Safety Switches



Figure 18

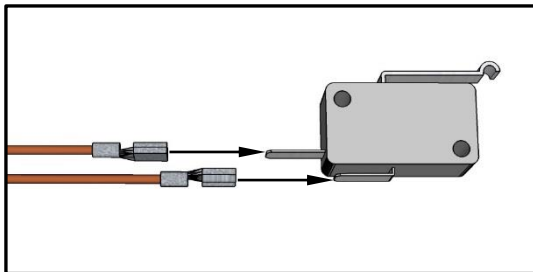

Figure 19

⚠ WARNING ⚠

**MAKE SURE A.C. POWER IS DISCONNECTED FROM DUMBWAITER!!
FAILURE TO DO SO COULD DAMAGE THE DUMBWAITER AND/OR
CAUSE SERIOUS BODILY INJURY, LOSS OF LIMB, OR DEATH!**

- 1** Mount one safety switch to the jam of each opening, (i.e. motor access panel/door, first floor, second floor, etc.), so that you can hear the switch click when opening and closing the door. (see Figure 18)

⚠ IMPORTANT ⚠

CODE REQUIRES ALL DUMBWAITERS TO HAVE A MOTOR ACCESS PANEL OR DOOR TO SERVICE THE DUMBWAITER SAFELY. THE MOTOR ACCESS PANEL OR DOOR MUST HAVE A SAFETY SWITCH. FAILURE TO INSTALL SAFETY SWITCHES AT ALL OPENINGS COULD CAUSE SERIOUS BODILY INJURY, LOSS OF LIMB, OR DEATH, AND MAY VOID YOUR WARRANTY

- 2** Connect “red” and “black” wires to door safety switch using the provided spade quick connectors. It does not matter which terminal the “red” and “black” wires are connected to. (see Figure 19)

NOTE: Unless additional safety switches were requested during the ordering process,

- 2-stop machines come standard with three (3) safety switches and the wiring harness has three (3) pairs of red and black wires with spade quick connectors.
- 3-stop machines come standard with four (4) safety switches and the wiring harness has four (4) pairs of red and black wires with spade quick connectors.
- 4-stop machines come standard with five (5) safety switches and the wiring harness has five (5) pairs of red and black wires with spade quick connectors.

- 3** Use electrical tape to cover the ends of the white and green wires separately. Failure to do this may short out the dumbwaiter when connected to the a.c. power supply.

⚠ IMPORTANT ⚠

SECURE WIRES DOWN TO JAM AND OR WALL TO PREVENT MOVING DUMBWAITER CAR FROM SNAGGING ON WIRES AND DAMAGING DUMBWAITER OR STRUCTURE.

PART 6c

Finish Wiring

Power to Motor

⚠ WARNING ⚠

DO NOT INSTALL DUMBWAITER CAR UNTIL PUSH BUTTONS AND DOOR SAFETY SWITCHES ARE PROPERLY INSTALLED, AND ALL ADJUSTMENTS ARE COMPLETE!! FAILURE TO DO SO COULD DAMAGE THE DUMBWAITER AND/OR CAUSE SERIOUS BODILY INJURY, LOSS OF LIMB, OR DEATH!

- 1** For 110V motors, use provided 3' (1.0 m) power cord to plug dumbwaiter in to a dedicated 20A circuit. For 220V motors, have a certified electrician connect the controller power bus to your dedicated 20A circuit.
- 2** Now that the dumbwaiter has power to it, close all doors to begin testing the functionality of the dumbwaiter.
NOTE: For steps 3 & 4 You will need two people to test the door safety switches.
One person will listen to the controller while holding down the motor access safety switch and the other person will be operating the doors.
- 3** Test the safety circuit by opening and closing one door at a time. As a door is opened and closed a clicking sound should be heard coming from the motor controller. This clicking sound will be different from the door safety switch click. If the controller is clicking when the door is opened and closed that door safety switch is working properly.
- 4** Test all door safety switches.
- 5** Now that all door safety switches have been tested and are working properly, open all doors and using one of the installed push button wall plates, try to send the dumbwaiter up. **THE DUMBWAITER SHOULD NOT BE WORKING!!**
- 6** Starting at the floor farthest from the motor, close the door and try to send the dumbwaiter up. Again, the dumbwaiter should not be working. Continue to the remaining floors and close one door at a time and try sending the dumbwaiter up until all doors are closed.
NOTE: If the dumbwaiter operates with a door open, unplug the dumbwaiter and call Powerlift Dumbwaiters, Inc. at 1-800-409-5438.
- 7** Now that the door safety switches are functioning properly, press the call send push buttons to test the dumbwaiters function up and back down.

⚠ IMPORTANT ⚠

IF ANY STRANGE NOISE, SCRAPING, CRASHING, OR BANGING, IS HEARD WHILE THE DUMBWAITER IS OPERATING, IMMEDIATELY OPEN A DOOR TO STOP THE DUMBWAITER, DISCONNECT THE POWER, AND CALL POWERLIFT DUMBWAITERS, INC. AT 1-800-409-5438.

DO NOT UNPLUG 3 OR 4 STOP DUMBWAITERS WHILE CAR IS BETWEEN FLOORS. IF STOPPED BETWEEN FLOORS, THE DUMBWAITER TROLLEY MUST BE MANUALLY RAISED OR LOWERED TO THE NEAREST FLOOR'S LIMIT SWITCH. (SEE TROUBLESHOOTING)

PART 6d

Finish Wiring

Door Lock Installation

RCI
RUTHERFORD CONTROLS
A DORMA Group Company

Installation Instructions

Dimensions:
 1-3/16" (30mm)
 2-3/8" (60mm)
 7/8" (22mm)
 1-1/4" (31mm)
 2-7/8" (73mm)
 3/8" (10mm)
 19/32" (15mm)
 3/8" (10mm)
 Min. 25/32" (20mm)
 11/16" (18mm)

Swinging Cabinet Door

Sliding Cabinet Door

Install rubber pad in between the mounting surface and catch to secure catch position.

© 2013 Rutherford Controls
www.rutherfordcontrols.com

IS3513
PCN15037
R07/15GR-2

⚠ WARNING ⚠

MAKE SURE A.C. POWER IS DISCONNECTED FROM DUMBWAITER!! FAILURE TO DO SO COULD DAMAGE THE DUMBWAITER AND/OR CAUSE SERIOUS BODILY INJURY, LOSS OF LIMB, OR DEATH!

1 The RCI door locks should be mounted opposite the hinges using the provided hardware.

⚠ IMPORTANT ⚠

THE M4 HEX HEAD SCREWS AND CAP NUTS ARE PROVIDED TO THROUGH BOLT THE CATCH TO THE DOOR. THE 30mm SCREWS ARE FOR USE ON 3/4" CABINET DOORS. THE 50mm SCREWS ARE FOR USE ON 1 1/4" FIRE RATED DOORS. THE CATCH MUST BE THROUGH BOLTED TO SERVICE THE DUMBWAITER SAFELY, WITHOUT DAMAGING THE DOORS

2 The black wire from the door lock connects to the green wire in the 4 wire safety circuit from junction box at opening. Use the provided dolphin connectors to crimp the wires together. (see Figure 20)

3 The red wire from the door lock connects to the white wire in the 4 wire safety circuit from junction box at opening. Use the provided dolphin connectors to crimp the wires together. (see Figure 20)

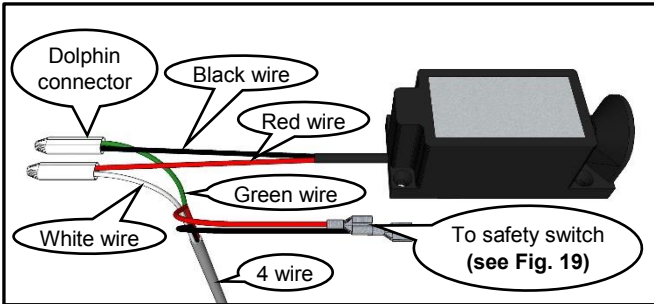

Figure 20

⚠ IMPORTANT ⚠

SECURE WIRES DOWN TO JAM AND OR WALL TO PREVENT MOVING DUMBWAITER CAR FROM SNAGGING ON WIRES AND DAMAGING DUMBWAITER OR STRUCTURE.

PART 7

Installing the Dumbwaiter Car

⚠ WARNING ⚠

DO NOT INSTALL DUMBWAITER CAR UNTIL PUSH BUTTONS AND DOOR SAFETY SWITCHES ARE PROPERLY INSTALLED, AND ALL ADJUSTMENTS ARE COMPLETE!! FAILURE TO DO SO COULD DAMAGE THE DUMBWAITER AND/OR CAUSE SERIOUS BODILY INJURY, LOSS OF LIMB, OR DEATH!

⚠ WARNING ⚠

MAKE SURE A.C. POWER IS DISCONNECTED FROM DUMBWAITER!! FAILURE TO DO SO COULD DAMAGE THE DUMBWAITER AND/OR CAUSE SERIOUS BODILY INJURY, LOSS OF LIMB, OR DEATH!

- 1** Removal of the RCI door lock may be necessary to install the dumbwaiter car.
- 2** Use provided bolts ($\frac{1}{4}$ "-20 x $1\frac{3}{4}$ ") & washers to secure dumbwaiter car to trolley. (see **Figure 21**)
- 3** When positioning car on trolley, make sure the tabs are hooked under car as shown in **Figure 22**.
- 4** Reinstall RCI door lock if removed for car installation.

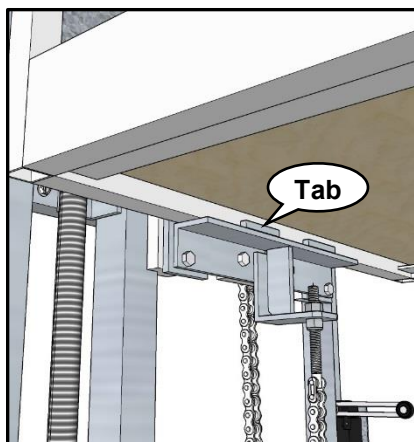

Figure 22

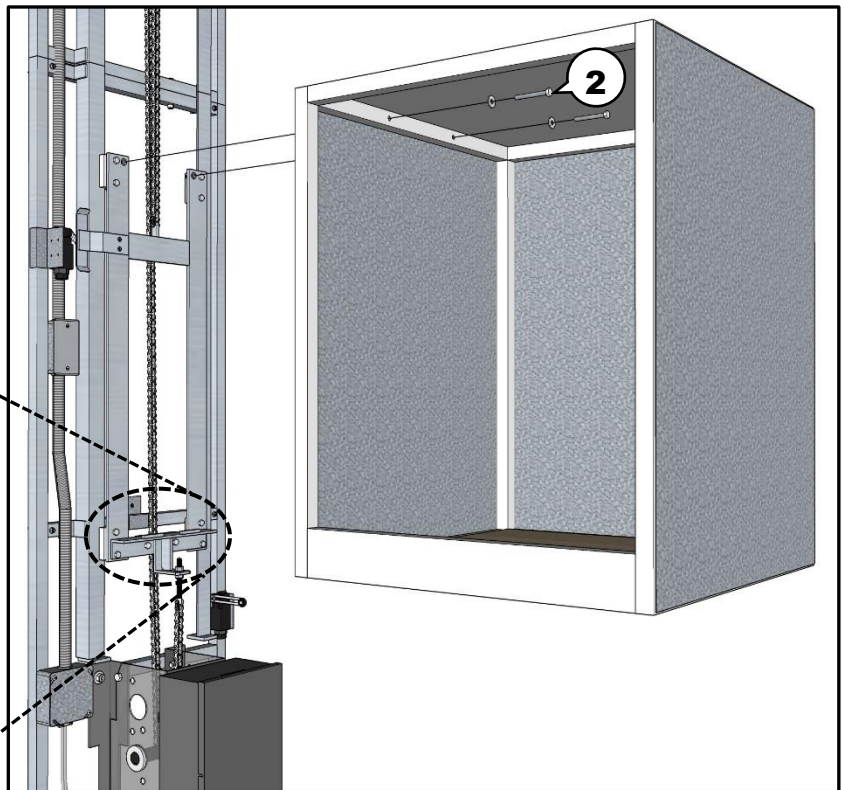

Figure 21

Troubleshooting

The following instructions refer to the wiring diagrams on:

Page 23 -- for 2-stop single phase machines

Page 24 -- for 3-stop three phase machines

Page 25 -- for 4-stop single phase machines

1 Verify that the dumbwaiter has a.c. power.

- A. Check the circuit breaker to see if it has been tripped and reset breaker.
- B. Check the overload "Reset" button, on the side of the controller box (see Page 8, Figure 1), to see if it has popped out and reset it, if necessary, by pushing it back in.

2 Check for 24 volts a.c. in control box.

- A. Use a volt meter to test the low voltage side of the transformer. Connecting volt meter leads to the brown and yellow wires should show at least 24V a.c.
- B. Check lighted relays 1 & 2 to see if both relays are lit.
 - I. If relay 2 is lit and relay 1 is not, go on to step 3.
 - II. If both are out, check the 2 amp fuse mounted inside the control box on the side. It is best to remove the fuse and check for burn marks. Replace if blown.

3 Test the safety circuit.

- A. On terminal bar, for 2 stop machines, short out terminals 6 and 7. For 3 and 4 stop machines, short out terminals 1 and 2.
 - I. If relay 1 clicks, the safety circuit is not complete, go on to step 4.
 - II. If relay 1 is lit and does not click, check the connections to the push buttons.

4 Manually moving dumbwaiter car.

- A. Verify all doors are closed and dumbwaiter car is not lower than the bottom floor opening or higher than the top floor opening.
 - I. If dumbwaiter car is not vertically out of alignment and still does not function, please call Powerlift Dumbwaiters, Inc.

⚠ WARNING ⚠

USING THE CONTACTORS TO MOVE THE DUMBWAITER CAR BYPASSES THE ENTIRE SAFETY CIRCUIT. HOLDING THE CONTACTOR IN COULD DAMAGE THE DUMBWAITER AND/OR CAUSE SERIOUS BODILY INJURY, LOSS OF LIMB, OR DEATH!

- II. If dumbwaiter car is vertically out of alignment, use the "UP" contactor to adjust the car up or use the "DOWN" contactor to adjust the car down.

Contactor operation

- With 2 stop machines, the contactor will stay in when pressed and the dumbwaiter car will automatically go to the nearest floor when working properly. If the contactor does not stay in, there is a low voltage problem. Please call Powerlift Dumbwaiters, Inc.
- With 3 & 4 stop machines, the contactor will never stay in. If power is lost while the dumbwaiter car is between stops, the contactors will work like a momentary contact switch, and may be used to bump the car up or down to the nearest floor. Once the car is aligned with an opening, the pc board will be reset and the dumbwaiter should function properly.

Troubleshooting

2-Stop Controller Wiring Diagram

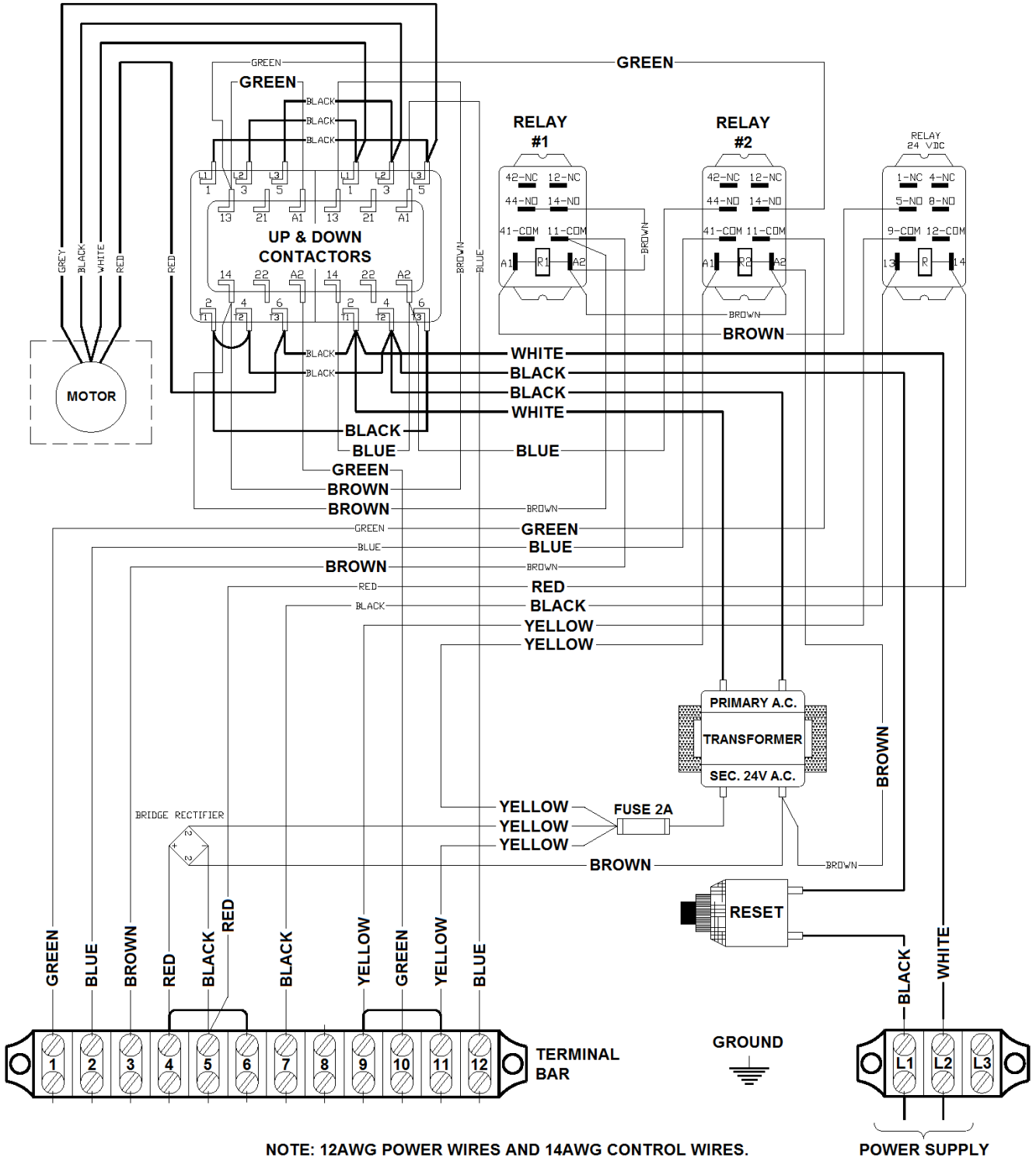

Troubleshooting

3-Stop Controller Wiring Diagram

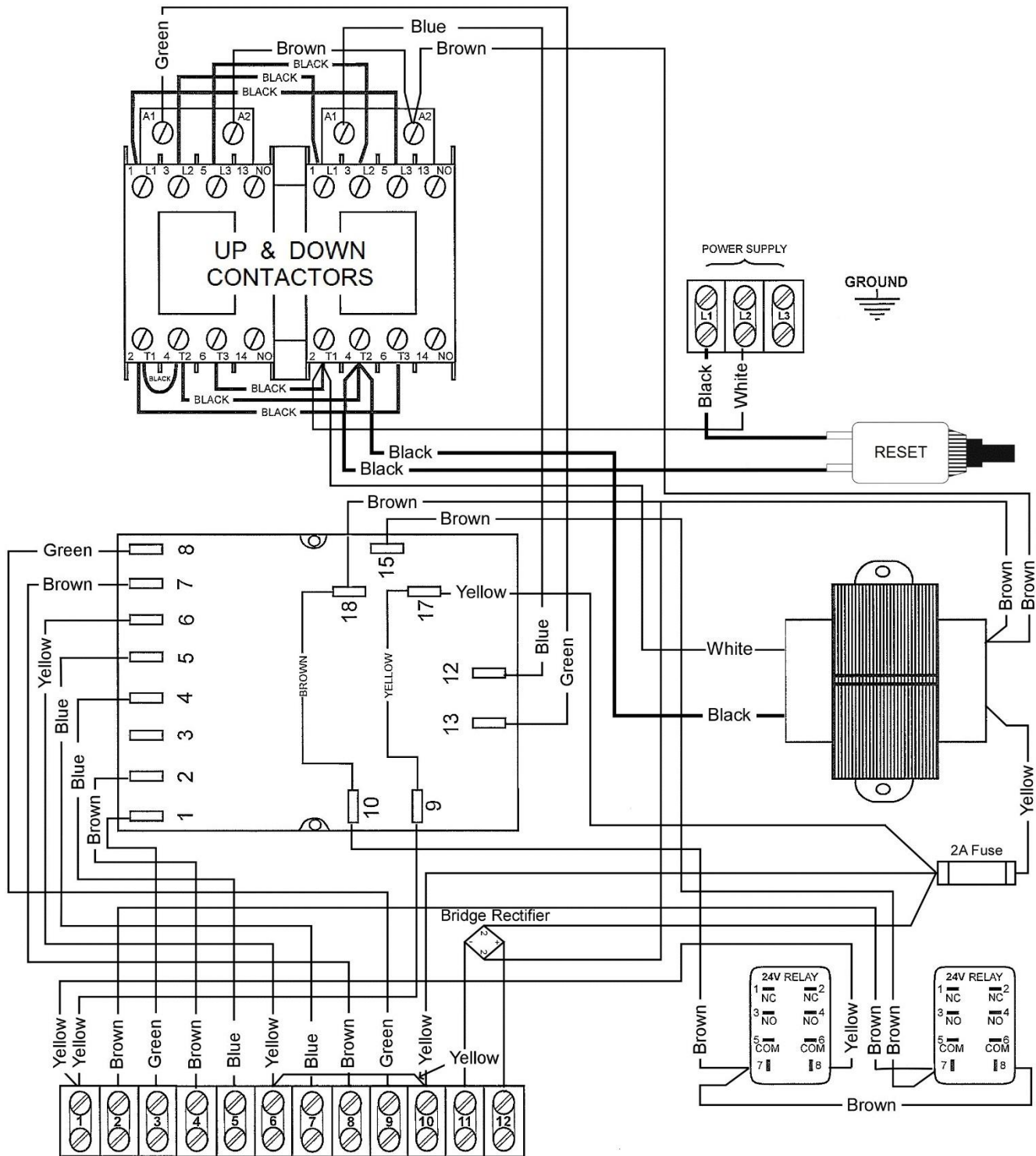

Troubleshooting 4-Stop Controller Wiring Diagram

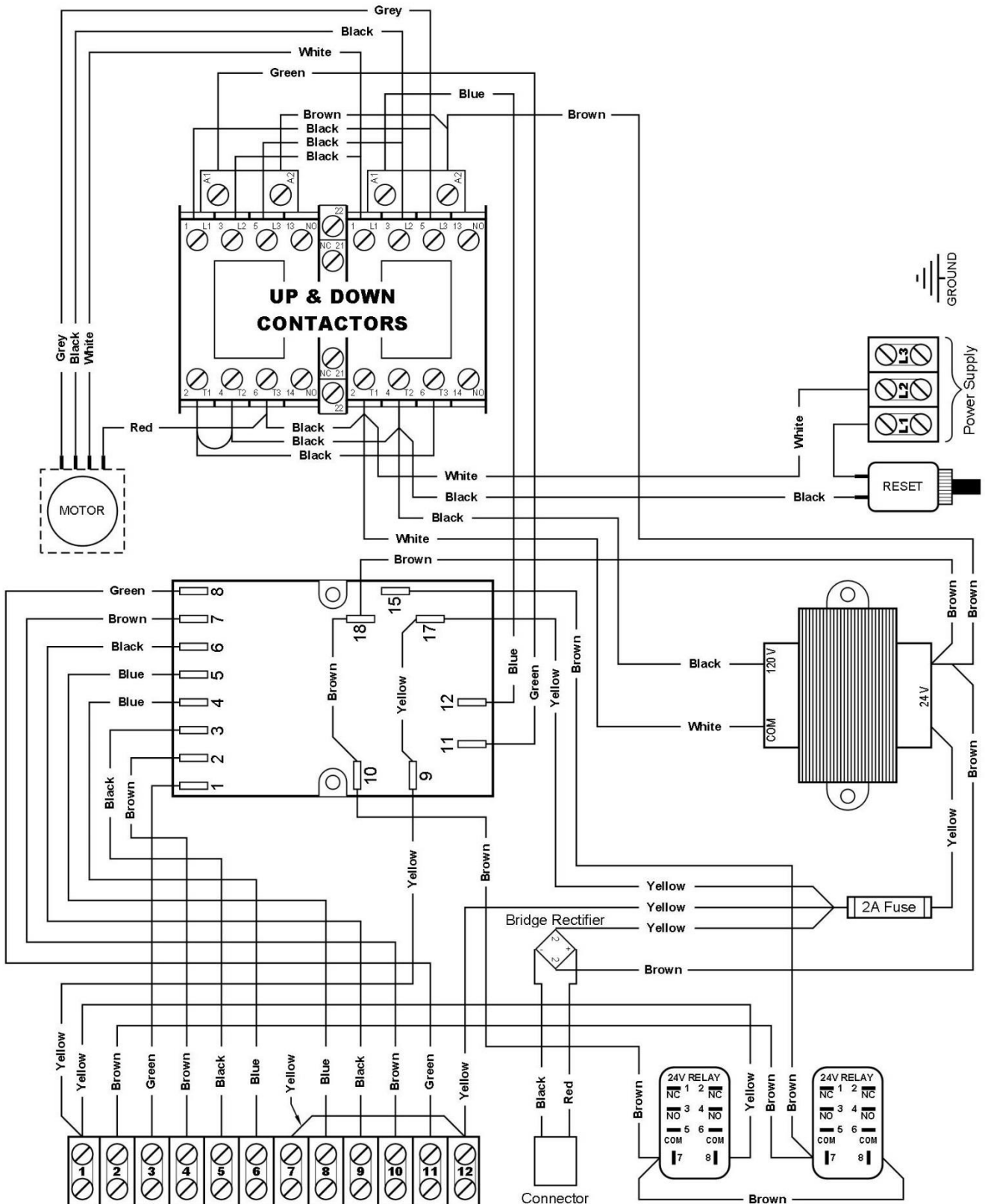

From all of us at
Powerlift Dumbwaiters, Inc.
Thank you for your business.
May God bless you and your family.

www.dumbwaiters.com

1-800-409-5438